



Thru-the-Wall Comfort

Heating & Cooling

Assembly Instructions

Wall Sleeve & Grille
for Comfort Pack Flex -
Package Heat Pump

GRILLE NOT INCLUDED W/ FCWS

Read Installation Manual
Prior To Starting The Installation.

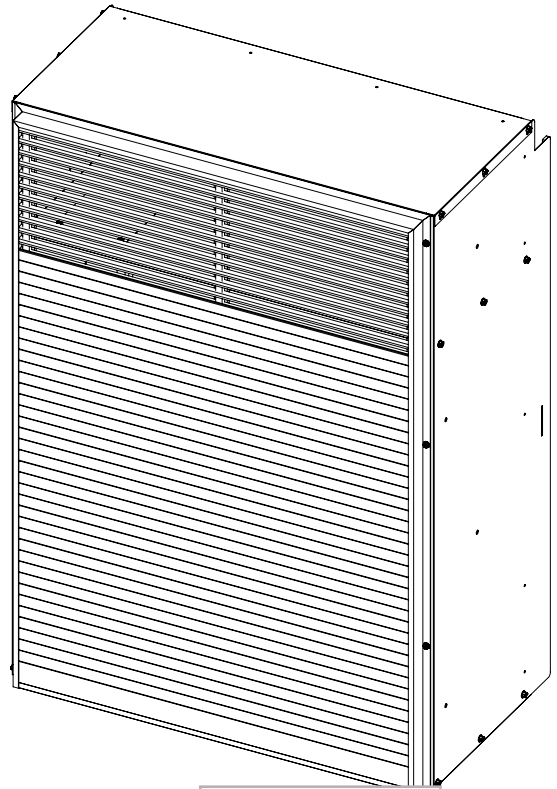

FCWS

NOTE: DUE TO VARIOUS TYPES OF WALL CONSTRUCTION, DETAILED INSTRUCTIONS ARE NOT PROVIDED FOR THRU-THE-WALL INSTALLATIONS. THE FOLLOWING GUIDELINES AND PRECAUTIONS SHOULD BE CONSIDERED.



National Comfort Products
A Division of National Refrigeration and Air Conditioning Products, Inc.
539 Dunksferry Road · Bensalem, PA 19020-5908
(800) 523-7138
www.nationalcomfortproducts.com

Go Thru-the-Wall

Assembly Instructions for Wall Sleeves (FCH)

1. Masonry walls must have a lintel to support the wall.
2. Verify the wall opening matches the dimensions provided in **Figure 1** below. The Wall Sleeve should be assembled so that the side panel flanges are on the same side. **The Louver or Grille should be mounted to that side (See Figure 2)**. Seal all wall sleeve joints during assembly with silicone or water proof sealant.

Figure 1 - Wall Sleeve Dimensions

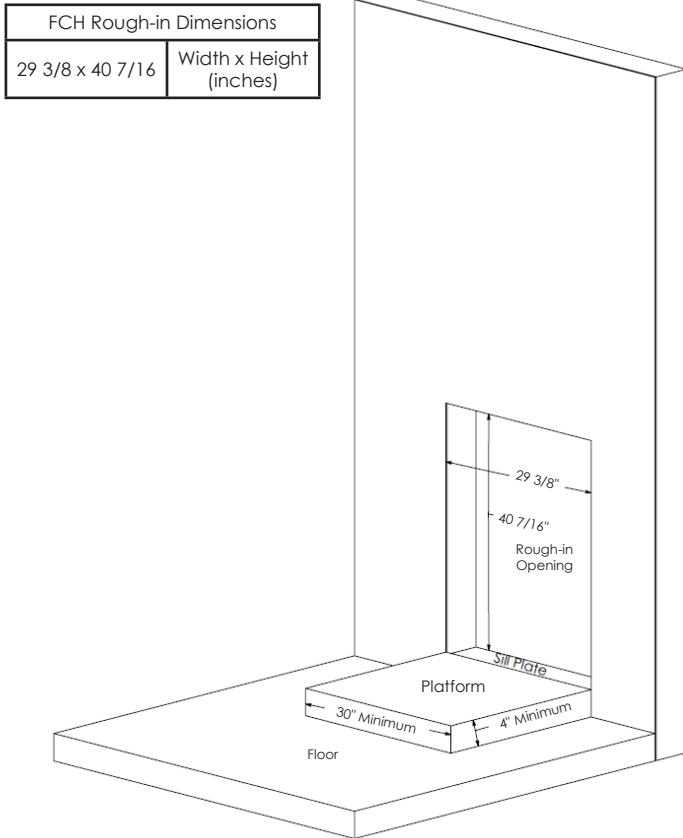

3. Before the wall sleeve can be assembled, a platform must be built to support the Comfort Pack Flex. The platform must be a minimum of 4" in height and 30" wide, as shown in **Figure 1**. Ensure top of the sill plate and the top of the platform are level.

Figure 2 - Wall Sleeve Assembly

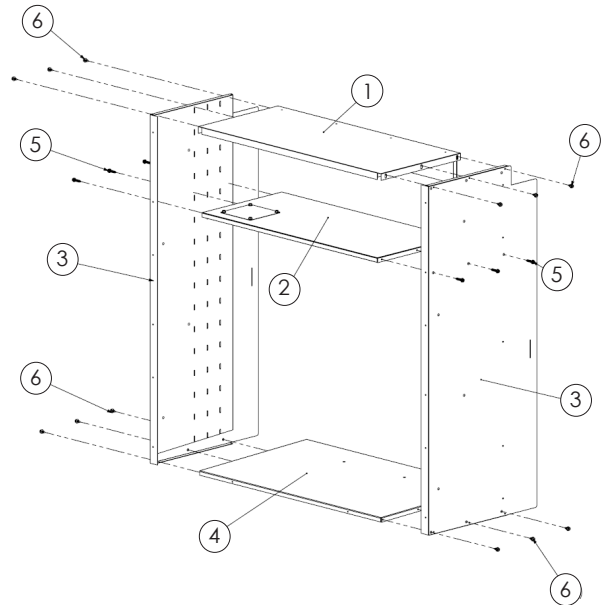

ITEM NO.	PART NUMBER	DESCRIPTION	QTY.
1		WALL SLEEVE TOP	1
2		WALL SLEEVE CENTER	1
3		WALL SLEEVE SIDE PANEL	2
4		WALL SLEEVE BASE PAN	1
5	142-95-064	12 X 1 HEX HEAD FASTENER	6
6	142-95-037	12 X 1/2 HEX HEAD FASTENER	12

4. Fasten louver grille to wall sleeve via the fasteners provided with louver, as shown in **Figure 3**.

Figure 3

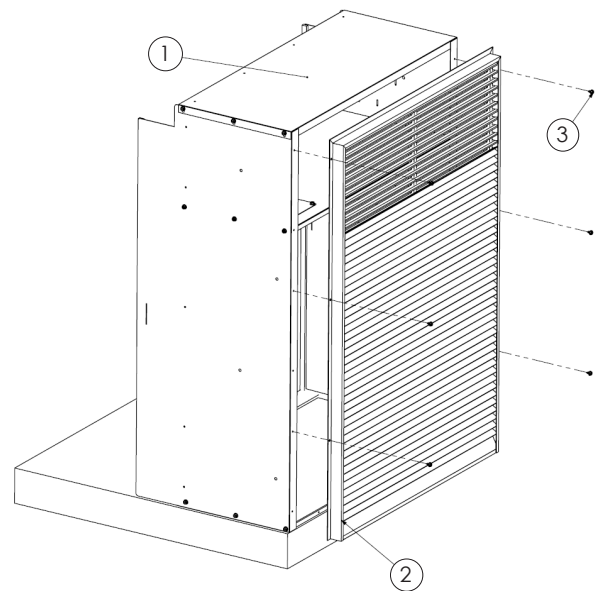

ITEM NO.	PART NUMBER	DESCRIPTION	QTY.
1	FCWS-**	WALL SLEEVE	1
2	142-69-038-S	SLEEVE MOUNTED LOUVER GRILLE	1
3		FASTENERS PROVIDED WITH LOUVER GRILLE	6

Assembly Instructions for Wall Sleeves (FCH)

5. The wall sleeve should be installed so that the wall sleeve base pan is flush or extend beyond the outside finished wall to prevent water entry. Ensure wall sleeve is flashed on all 4 sides to prevent water entry. (Note: The louver and wall sleeve are separate items. Wall sleeve must be flush or extended beyond wall. Louver will extend beyond wall sleeve)(See Figure 4).

Figure 4 - Installation

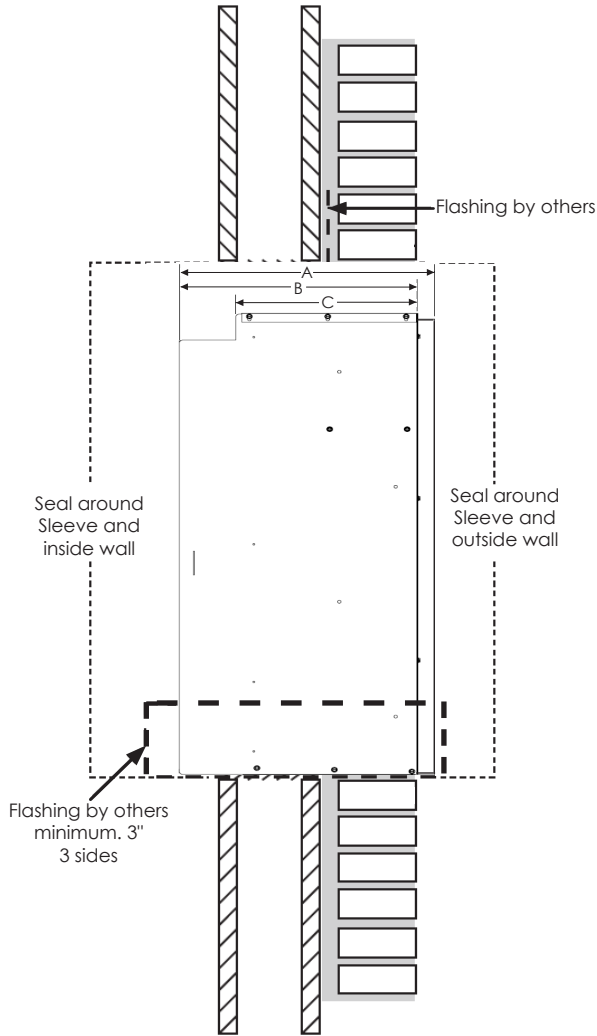

WALL SLEEVE OPTION	A	B	C
12"	16 1/8"	14 7/8"	12 7/8"
10"	14 1/8"	12 7/8"	10 7/8"
8"	12 1/8"	10 7/8"	8 7/8"
6"	10 1/8"	8 7/8"	6 7/8"

6. Make sure wall sleeve is square before securing to platform and wall. Use factory supplied 1 1/2" fasteners to secure base pan to platform, as shown in Figure 5.

Figure 5

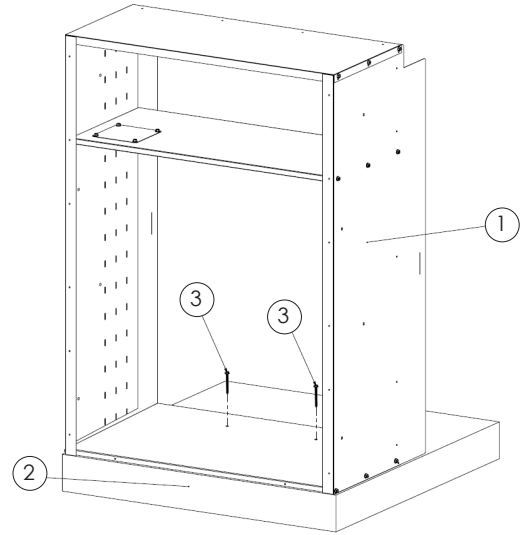

ITEM NO.	PART NUMBER	DESCRIPTION	QTY
1	FCWS-**	WALL SLEEVE	1
2	Field Supplied	4" PLATFORM	1
3	142-95-069	#10 x 1 1/2" HEX HEAD FASTENERS	2

WARNING: SLEEVE MUST BE FASTENED TO THE WALL STUDS AND NOT THE FINISHED WALL.

7. Once base pan is secure to platform, attach the side and top mounting brackets to the wall sleeve using the #12 x 1/2" fasteners. Then secure the bracket onto the interior wall using the #10 x 1 1/2" fasteners. If the mounting brackets are not used, utilize the eight mounting holes in the side panels to secure the sleeve to the wall directly. Ensure that all unused holes are sealed so no water enters the closet or walls

Figure 6

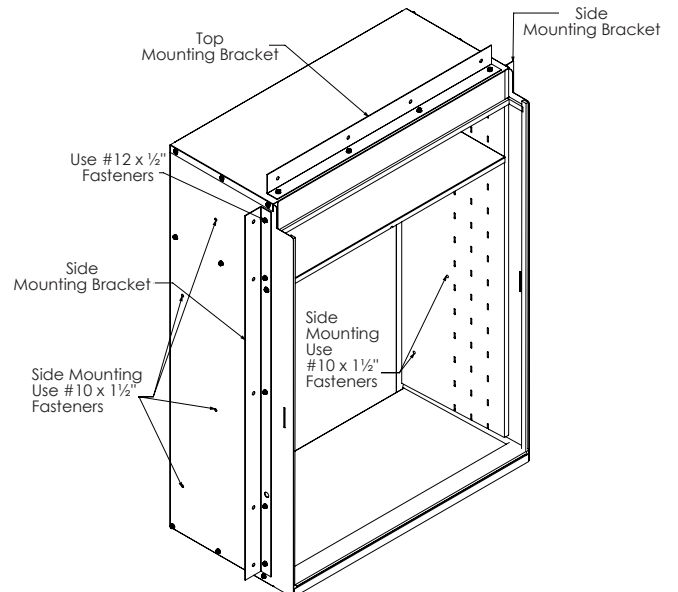

Assembly Instructions for Wall Sleeves (FCH)

- The wall opening across the top and bottom of the wall sleeve must be flashed. All openings around the top, sides and bottom must be caulked and sealed.
- Ensure gasket strips are along the side panels, base pan, and top panel as shown in **Figure 7**.

Figure 7

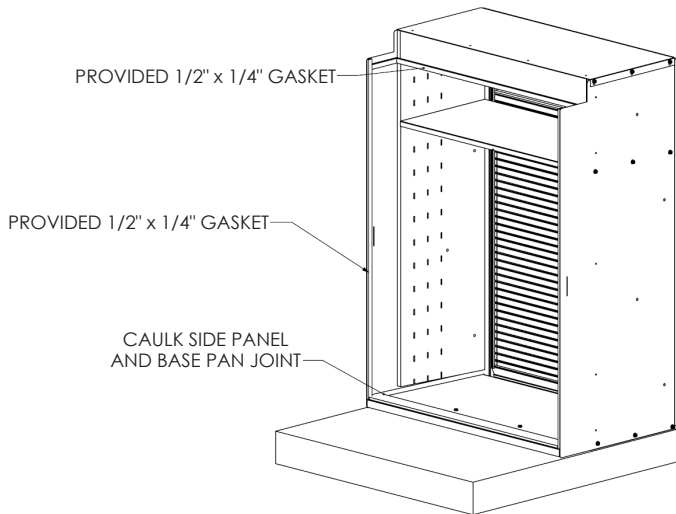
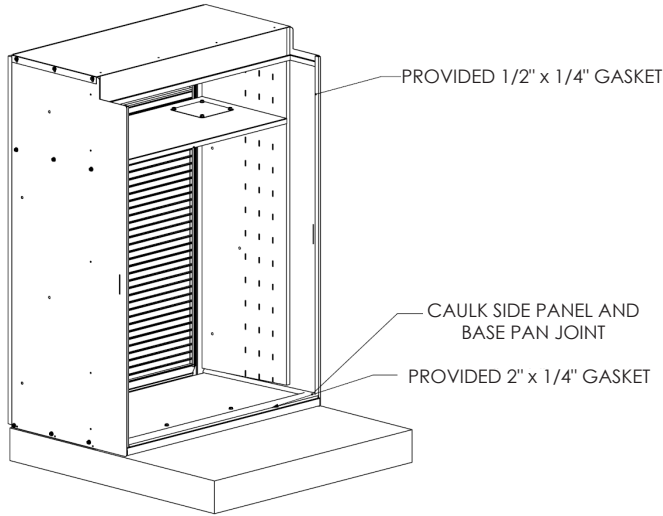

- All unused holes need to be sealed.
- Insert wall sleeve brace by hooking the hem into the slot on each side of the wall sleeve side panel. This will ensure the unit is in the correct position when inserting into the wall sleeve. Once the unit is installed in wall sleeve, the holes on the brace and the unit side panel should line up. Fasten the brace and unit together using the #12 x 1/2" fastener.

Figure 8

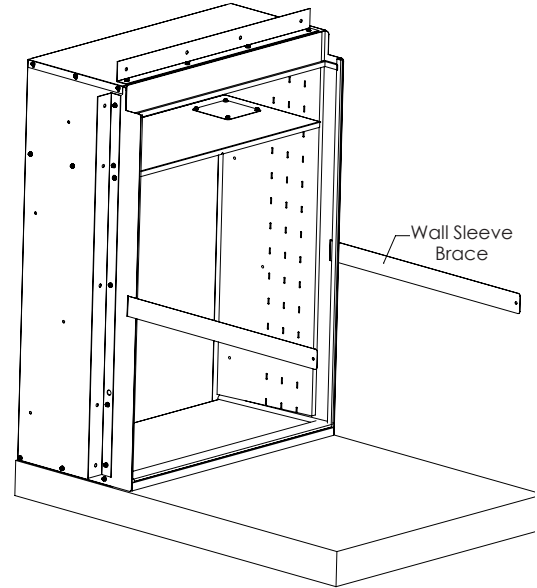

NOTE: COMPLETELY FILL ANY SPACE BETWEEN THE WALL SLEEVE SIDE PANELS AND THE SIDES OF THE UNIT WITH A POLYURETHANE FOAM SEALANT. ALL GAPS MUST BE FILLED TO PREVENT WATER ENTRY AND POSSIBLE DAMAGE TO THE CLOSET. (FOLLOW THE SEALANT MANUFACTURER'S SUGGESTED APPLICATION INSTRUCTIONS).

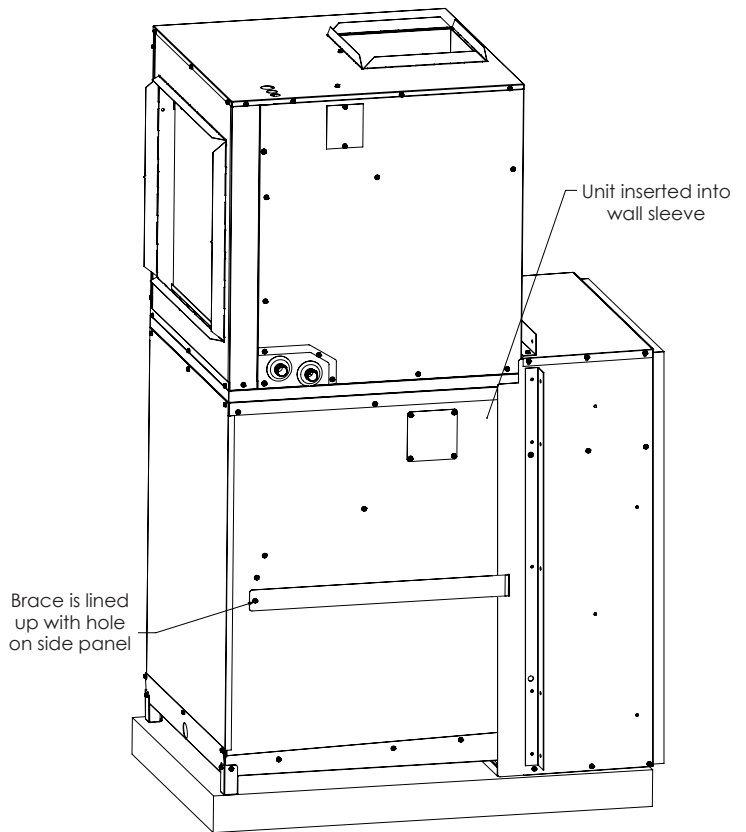

National Comfort Products
A Division of National Refrigeration and Air Conditioning Products, Inc.
539 Dunksferry Road · Bensalem, PA 19020-5908
(800) 523-7138
www.nationalcomfortproducts.com