

Thru-the-Wall Comfort

Heating & Cooling

Installation Guide

Thru the Wall Heat Pump

This unit should be installed in an
**Outside Wall For
Thru-The-Wall
Installation Only!**

Read Installation Manual
Prior To Starting The Installation.

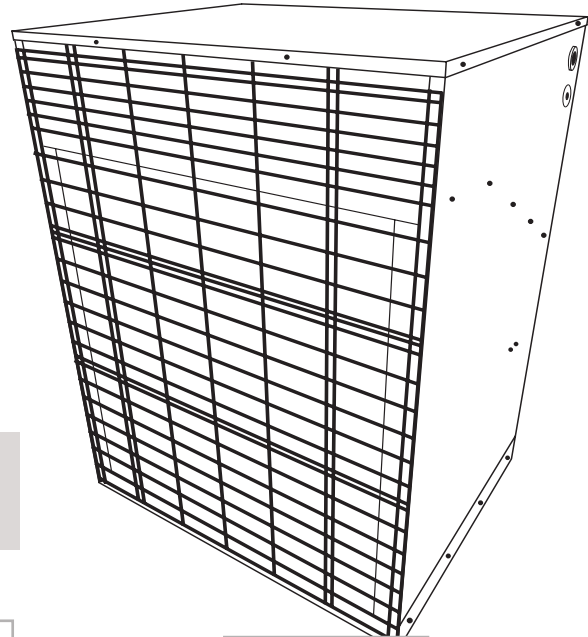

NHP
Series:
3000
5000

Please fill in the following information and file it for future reference.

MODEL NO. _____

SERIAL NO. _____

INSTALL DATE _____

This manual must be left with the homeowner for future reference.

All Units Department of Energy Listed

*Please consult the DOE Compliance Certification Database (<https://tinyurl.com/NCP-Condensers>) for a list of rated combinations of indoor and outdoor units.



National Comfort Products
A Division of National Refrigeration and Air Conditioning Products, Inc.
539 Dunksferry Road · Bensalem, PA 19020-5908
(800) 523-7138
www.nationalcomfortproducts.com



Go Thru-the-Wall

	Page
Nomenclature.....	4
Safety Warning	5
Before You Start.....	6
Check for Clearances	7
Unit Location Considerations	7
Refrigerant Piping Limits	8
Leak Checking.....	9
Evacuation	10
Electrical Connections.....	11
High Voltage and Power Supply.....	11
Start Up, Sequence of Operations	12
Refrigerant Charging.....	12
Maintenance.....	17
Checkout Procedure.....	18
Decommissioning/Recovery	18
Noise, Insulated Sound Cover	19
Important! Before Removing a Warranty Compressor.....	20
Wiring Diagrams.....	21
Specifications, Dimensional Drawings.....	22-23
Matched systems with Air Handlers.....	24
Replacement Parts - NHP 3000 Series.....	25
Replacement Parts - NHP 5000 Series.....	26
Warranty	27-28

**IMPORTANT NOTE: DO NOT DESTROY OR THROW AWAY THIS MANUAL.
IT SHOULD BE KEPT IN A SAFE PLACE FOR FUTURE REFERENCE.**

Thru the Wall Heat Pump Nomenclature

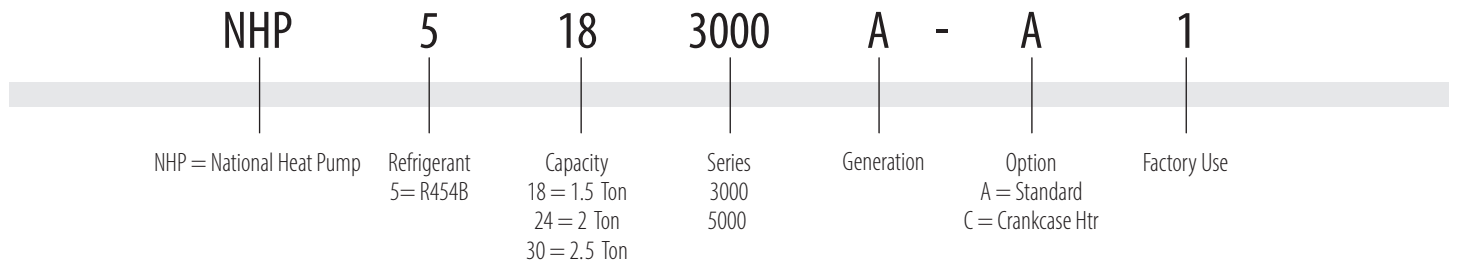

⚠ ATTENTION FOR SYSTEM CHARGING

THIS UNIT IS CHARGED WITH 3.75Lbs (1.7Kg) OF REFRIGERANT TO BE STORED SAFELY. THE SYSTEM WILL REQUIRE ADDITIONAL R454B CHARGE DURING INSTALLATION. REFER TO PAGE # 12 & 24 FOR PROPER CHARGE ADJUSTMENTS.

Safety Warnings!

This appliance is not intended for use by those (including children) with reduced physical, sensory or mental capabilities, or lack of experience and knowledge, unless they have been given supervision or instructions concerning use of the appliance by a person responsible for their safety. Children should be supervised to ensure that they do not play with the appliance.

This appliance is intended to be installed up to 10,000 ft (3,000 m) above sea level.

This appliance is only compatible with an indoor unit that uses **R454B** refrigerant.



When installing this unit with an indoor evaporating unit, the maximum operating pressure is to be considered during the installation. The maximum operating pressure of the system should not exceed the value as indicated on the nameplate of this condensing unit.

This model series NHP5*****_** is a PARTIAL UNIT heat pump, complying with PARTIAL UNIT requirements of the International Standard of UL-60335-2-40, and must only be connected to the other units that have been confirmed as complying to corresponding PARTIAL UNIT requirements of the International Standard of UL-60335-2-40.

⚠ This is a safety alert symbol. When you see this symbol on labels or in manuals, be alert to the potential for personal injury.

Pay particular attention to words such as **DANGER**, **WARNING** or **CAUTION**.

DANGER indicates an imminently hazardous situation, which will result in **serious injury or death**.

WARNING indicates a potentially hazardous situation, which could potentially result in **serious injury or death**.

CAUTION indicates a potentially hazardous situation, which may result in **minor or moderate injury**. It is also used to alert against practices that are unsafe and can result in property damage.

⚠ WARNING

HIGH VOLTAGE! Disconnect ALL power before servicing. Multiple power sources may be present. Failure to do so may result in property damage, personal injury or death.

⚠ AVERTISSEMENT

HAUTE TENSION! Débranchez TOUTE l'alimentation avant l'entretien. Plusieurs sources d'alimentation peuvent être présentes. Le non-respect de cette consigne peut entraîner des dommages matériels, des blessures corporelles ou la mort.

⚠ WARNING

These instructions are intended as an aid to qualified, licensed service personnel for proper installation, adjustment and operation of this unit. **Read these instructions thoroughly before attempting installation or operation.** Failure to follow these instructions may result in improper installation, adjustment, service or maintenance possibly resulting in fire, electrical shock, property damage, personal injury or death.

⚠ AVERTISSEMENT

Ces instructions sont destinées à aider le personnel de service qualifié et agréé pour l'installation, le réglage et le fonctionnement corrects de cet appareil. **Lisez attentivement ces instructions avant de tenter l'installation ou l'utilisation.** Le non-respect de ces instructions peut entraîner une installation, un réglage, un entretien ou un entretien incorrects, ce qui peut entraîner un incendie, un choc électrique, des dommages matériels, des blessures corporelles ou la mort.

⚠ WARNING

All working personnel for maintenance, service, and repair operations must be certified from a national training organization or manufacturer that is accredited to teach the relevant national competency standards. Attempting to install or repair this unit without such background may result in product damage, personal injury or death.

⚠ AVERTISSEMENT

Tout le personnel de travail pour les opérations d'entretien, de service et de réparation doit être certifié par un organisme de formation national ou un fabricant accrédité pour enseigner les normes de compétence nationales pertinentes. Tenter d'installer ou de réparer cette unité sans un tel arrière-plan peut entraîner des dommages au produit, des blessures corporelles ou la mort.

⚠ CAUTION

Use care when handling scroll compressors. Some temperatures could be hot!

⚠ PRUDENCE

Soyez prudent lorsque vous manipulez des compresseurs à spirale. Certaines températures peuvent être chaudes!

⚠ CAUTION

Scroll compressors should NEVER be used to evacuate the air conditioning system. Vacuums this low can cause internal electrical arcing resulting in a damaged or failed compressor.

⚠ PRUDENCE

Les compresseurs à spirale ne doivent JAMAIS être utilisés pour évacuer le système de climatisation. Des vides aussi bas peuvent provoquer un arc électrique interne entraînant un compresseur endommagé ou défaillant.

⚠ WARNING

The unit must be permanently grounded. **Failure to do so can cause electrical shock resulting in severe personal injury or death.**

⚠ AVERTISSEMENT

L'unité doit être mise à la terre en permanence. **Le défaut de le faire peut provoquer un choc électrique entraînant des blessures graves ou la mort.**

“USE COPPER SUPPLY WIRES ONLY”**⚠ WARNING**

Do not use oxygen to purge lines or pressurize system for leak test. Oxygen reacts violently with oil, which can cause an explosion resulting in severe personal injury or death.

⚠ AVERTISSEMENT

N'utilisez pas d'oxygène pour purger les conduites ou pressuriser le système pour l'essai d'étanchéité. L'oxygène réagit violemment avec l'huile, ce qui peut provoquer une explosion entraîne des blessures graves ou la mort

⚠ WARNING

Extreme caution should be exercised when opening the Liquid Line Service Valve. Turn counter clockwise until the valve stem just touches the rolled edge. No torque is required. Failure to follow this warning will result in abrupt release of system charge and may result in personal injury and /or property damage.

⚠ AVERTISSEMENT

Une extrême prudence doit être exercée lors de l'ouverture de la vanne de service de la conduite de liquide. Tournez dans le sens inverse des aiguilles d'une montre jusqu'à ce que la tige de soupape touche simplement le bord roulé. Aucun couple n'est requis. Le non-respect de cet avertissement entraînera une libération abrupte des frais du système et peut entraîner des blessures corporelles et / ou des dommages matériels.

⚠ WARNING

Do not use means to accelerate the defrosting process or to clean, other than those recommended by the manufacturer.

The appliance shall be stored in a room without continuously operating ignition sources (for example: open flames, an operating gas appliance or an operating electric heater).

Do not pierce or burn.

Be aware that refrigerants may not contain an odor.

⚠ AVERTISSEMENT

N'utilisez pas de moyens pour accélérer le processus de dégivrage ou pour nettoyer, autres que ceux recommandés par le fabricant.

L'appareil doit être stocké dans une pièce sans sources d'inflammation fonctionnant en continu (par exemple : flammes nues, un appareil à gaz en fonctionnement ou un radiateur électrique en fonctionnement).

Ne pas percer ou brûler.

Sachez que les réfrigérants peuvent ne pas contenir d'odeur.

Before You Start

ALL phases of this installation must comply with NATIONAL, STATE AND LOCAL CODES. The manufacturer assumes no responsibility for equipment installed in violation of any code requirements.

Be sure that the electrical data specified on the unit rating plate corresponds to what is available at the installation site and NEC for installation requirements.

This unit MUST be installed in an outside wall for thru-the-wall installation ONLY. No pad mounts.

Be sure that the electrical service provided to the building can handle the load imposed by the unit.

IMPORTANT — This Document is customer property and is to remain with this unit. Please refer to service information pack upon completion of work to register the unit's warranty. These instructions do not cover all variations in systems or provide for every possible contingency to be met in connection with the installation. Should further information be desired or should particular problems arise which are not covered sufficiently for the purchaser's purposes, the matter should be referred to your installing dealer or local distributor before contacting the manufacturer.

The unit must **never** be placed on its side or upside down as the compressor oil will run in the cooling circuit and seriously damage the unit. Base pan must always be on the bottom of the install.

Check for Clearances

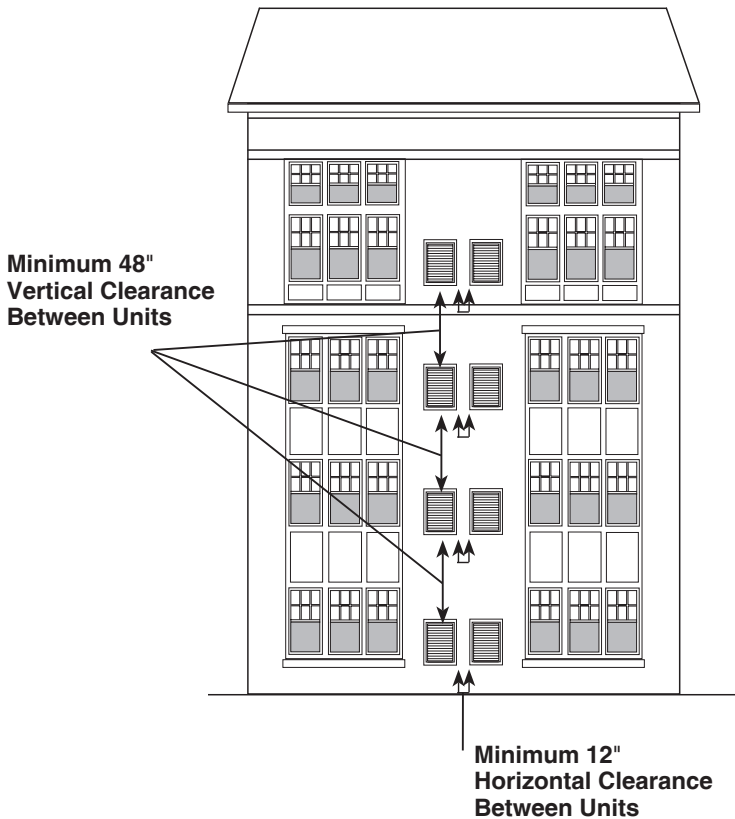

WARNING: Warranty will be void on all units installed behind brick facades (e.g. pigeon holes) or connected to ductwork (See Note 1 below). All obstacles added to impede air flow of the heat pump will decrease performance, cause premature equipment failure, and void all warranties. Consult factory with any questions.

Note 1: No ducts are permitted to be connected to the intake or discharge of the unit.

WARNING: The area where the appliances is installed shall be constructed that should any refrigerant leak, it will not stagnate so as to create a fire or explosion hazard.

Unit Location Considerations

In thru-the-wall installation, due to the various types of wall construction, it is not possible to provide detailed instructions. The following is a list of general requirements and cautions for installing these units. **The unit must be installed level, both - top front to back and left to right.**

- Masonry walls must have a lintel to support the wall.
- Extend the unit approximately 3/4" beyond outside surface of the wall. Optional mounting angles can be purchased from the factory or field fabricated for locating and mounting the unit in the wall.
- The wall opening across the top and bottom must be flashed. Bottom flashing to cover the full footprint of unit and extend up 2" on 3 sides. **All openings around the top, sides and bottom must be caulked and sealed. Care must be taken not to plug the openings in the front of the base pan of the unit. If the optional wall sleeve is used, caulk the spaces between the sleeve and the wall. Completely fill the clearance between the unit and the wall sleeve with a polyurethane foam sealant.**
- During periods of rain and wind the primary drainage path may not be adequate to handle the load. Secondary precautions may also be required but not limited to the following:
 - Seal flashing to unit
 - Floor drain
 - Additional field sealing of sheet metal joints
 - Sealing of unused access opening
- Clearances to air inlets and outlets must be adequate to ensure no air flow obstructions or recirculation of condenser air flow. Care must be taken to locate the coil side of the unit away from loose debris that may clog airflow inlet or outlet.
- Some architectural designs of buildings will require the unit to be mounted behind a decorative grille. The performance (capacity and efficiency) of the unit may be reduced with the use of these decorative grilles. The less resistive these grilles are to air flow, the better the units performance will be. Outdoor louvers provided by others **must be** approved by NCP to maintain unit performance and warranty.
- If the unit is mounted behind a decorative grille, one or both of the following items **must be** done to eliminate recirculation of air to the unit:
 - The front of the unit must be mounted tight to the inside of the architectural grille
 - A barrier must be provided to prevent recirculation of air to the unit (mixing of inlet and outlet air) when the front of the unit is mounted back from the inside of the architectural grille
- The unit must not be mounted in dead-end hallways or areas where there is no fresh outside air circulation. Cool fresh outside air **must be** provided for best unit operation. Thru-the-wall units may not be located where hot exhausts from clothes dryer vents, kitchen vents, steam vents or corrosive fumes could come in contact with coil side of unit.
- 30" clearance is required for service accessibility on the inside service panel.
- A minimum 48" of vertical clearance and 12" of horizontal clearance between units is required to minimize recirculation of condenser exhaust air. For horizontal clearances less than 12", please consult National Comfort Products.
- Care must be taken when locating the unit. Locate away from bedrooms as operational sounds may be objectionable. (See sound cover on page 17)
- The NHP heat pump is provided with a condensate pan including a 3/4" MPT drain connection. Provisions must be made for field piping to the building drain system for condensate disposal in accordance with local codes. Field piping to the drain connection must be pitched down and maybe done through the rear flange of the unit.
- A minimum 8" clearance between unit base pan and floor is required when installing unit.

Refrigerant Piping

All pipe-work shall include protection from physical damage in operation and service, and be in compliance with national and local codes and standards, such as ASHRAE 15, ASHRAE 15.2, IAPMO Uniform Mechanical Code, ICC International Mechanical Code, or CSA B52. All field joints shall be accessible for inspection prior to being covered or enclosed.

1. The maximum length of refrigerant lines from the through the wall unit to indoor unit should NOT exceed **fifty (50) feet** without contacting National Comfort Products. Pipe-work shall be kept to a minimum.
2. The maximum vertical change should not exceed twenty (20) feet without contacting National Comfort Products.

Maximum Allowable Liquid Line Pressure Drop = 50 PSI
Subtract .43 PSI for each foot of Liquid Lift (if any)
Do Not Exceed this value when selecting Liquid Line

3. The unit has internally mounted service valves. Field tubing may be routed through the locations provided in either the top or rear panels. Care should be taken not to block access to internal components. Seal unused knockouts with high grade sealant. Gaskets are provided for liquid and suction lines.

Note: Always use refrigeration grade copper tubing that is internally clean and dry for refrigerant lines. Use clean hard drawn copper tubing if no appreciable amount of bending is necessary. If soft copper is used, avoid sharp bends which may cause a restriction. Always use heat sink materials during brazing to prevent damage to service valves (See page 9). Low temperature solder alloys, such as lead or tin alloys, are not acceptable for pipe connections. Alloys used to join refrigerant containing connections shall have a melting point greater than 427°C (800°F).

4. A brazed, welded, or mechanical connection shall be made before opening the valves to permit refrigerant to flow between the REFRIGERATING SYSTEM parts. A vacuum valve shall be provided to evacuate the interconnecting pipe or any uncharged REFRIGERATING SYSTEM part.

Mechanical connectors used indoors shall comply with ISO 14903. When mechanical connectors are reused indoors, sealing parts shall be renewed. When flared joints are reused indoors, the flare part shall be refabricated.

All field applied joints shall be at least one of the following:

- Mechanical joints in compliance with ISO 14903 or UL 207 (U.S. only);
- Welded or brazed joints; or
- Joints in enclosures that vent to the unit or to the outside.

5. Run refrigerant lines as directly as possible. Field piping inside the heat pump should not block access to major components. Refrigerant lines should not be in direct contact with the floor or ceiling joists. Use insulated or suspension type hangers. When refrigerant lines run through a wall, seal openings around the lines with a flexible material to avoid vibration to the structure.

Note: Take precautions to prevent noise within the building structure due to vibration transmission from the refrigerant lines. For example:

When the refrigerant lines have to be fastened to floor joists or other framing in a structure, use isolation type hangers.

Isolation hangers should also be used when refrigerant lines are run in stud spaces or enclosed ceilings.

Where the refrigerant lines run through a wall or sill, they should be insulated and isolated.

Isolate lines from all ductwork.

Minimize the number of 90° turns.

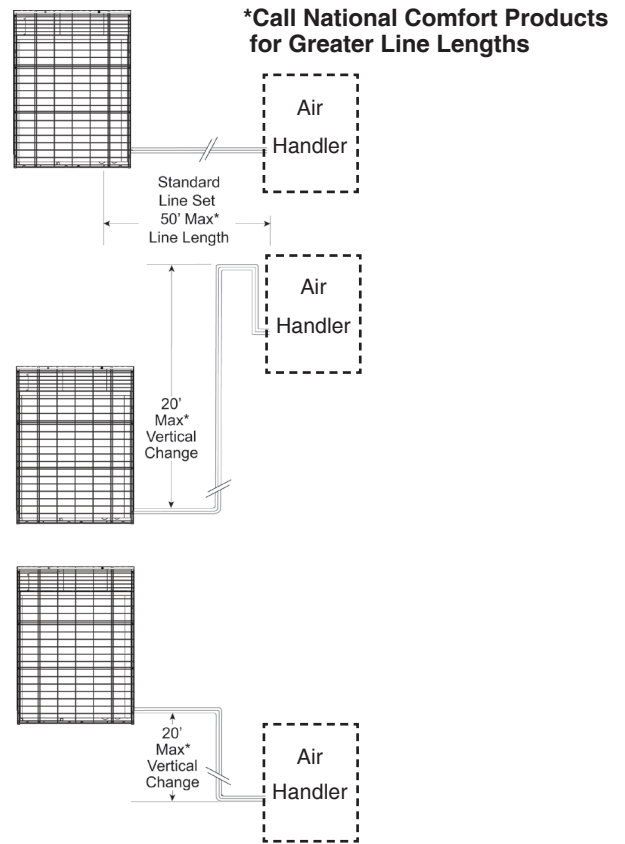

6. Standard refrigeration piping practices must be employed when installing traps. When installing the condenser below the evaporator, the suction line must be trapped with an inverted trap the height of the evaporator coil. Consult the factory when total equivalent length of refrigerant lines exceeds 50 ft.

7. Insulate the vapor line with a minimum 1/2" foam rubber or other type insulation having an adequate vapor barrier. For indoor unit with a TXV, a bi-flow liquid line filter drier must be installed.

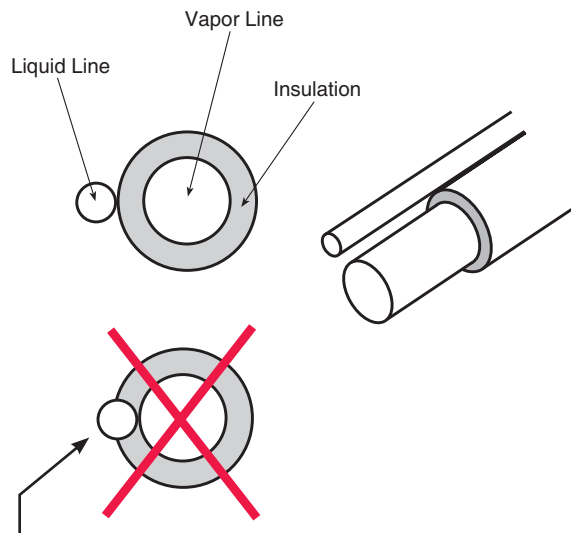

IMPORTANT: The Vapor Line must always be insulated. **DO NOT** allow the liquid line and vapor line to come in direct (metal to metal) contact.

8. Install the refrigerant lines using the following procedure (See Steps 1 thru 4.)

- a. Remove the service port caps and Schrader Cores of the liquid line service valve and the vapor line service valve of the condensing unit. Connect low pressure dry nitrogen to the liquid line valve service port.

CAUTION: Dry nitrogen should always be supplied through the tubing while it is being brazed, as the high temperature required for brazing will cause oxidation of the copper unless an inert atmosphere is provided. The flow of dry nitrogen should continue until the joints have cooled. Always use a pressure regulator and safety valve to ensure that only low pressure nitrogen is introduced into the tubing. Only a small flow is necessary to displace air and prevent oxidation.

- b. Provide a heat sink at the service valve such as wrapping a wet rag around it, to prevent damage during the brazing operation
- c. Braze the liquid line to the service valve. Allow the nitrogen to keep flowing when brazing the refrigerant line until all brazed joints are completed.
- d. Provide a heat sink to the vapor line service valve of the condensing unit
- e. Braze the vapor line to the service valve
- f. When tubing installation is complete, seal openings around tubing where tubing enters the unit cabinet.

Step 1:

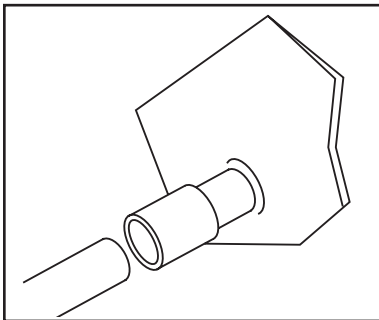

The tubing should be cut square. Make sure it is round and free of burrs at the connecting ends. Clean the tubing to prevent contaminants from entering the system.

Step 2:

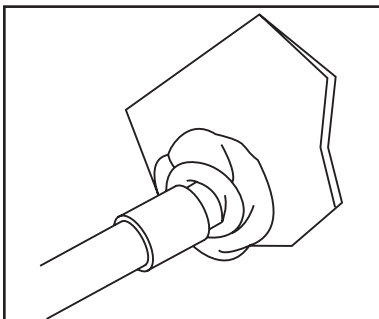

Wrap a wet rag around the copper stub of the service valve before brazing.

Step 3:

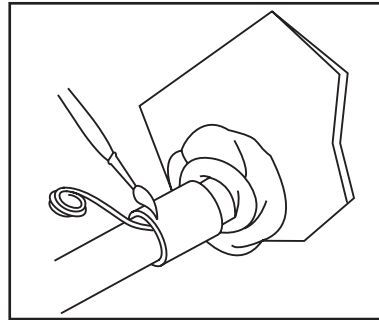

Flux the copper tube and insert into the stub. Braze the joint. No flux is necessary if a low to zero-silver braze alloy is used.

Step 4:

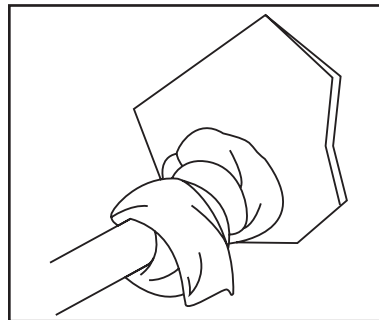

After brazing, quench with a wet rag to cool the joint and remove any flux residue.

Leak Checking

Under no circumstances shall potential sources of ignition be used in the searching for or detection of refrigerant leaks. A halide torch (or any other detector using a naked flame) shall not be used.

Field-made refrigerant joints indoors shall be tightness tested. The test method shall have a sensitivity of 5 grams per year of refrigerant or better under a pressure of at least 157 psig. No leak shall be detected.

Leak checking of refrigerant line braze joints and evaporator unit using dry nitrogen. (See Step 5a)

1. Replace service port cap of the vapor line service valve (cap was removed for brazing operations).
2. Connect dry nitrogen source to the service port of the liquid line service valve. Pressurize refrigerant lines and indoor coil to approximately 157 psig.
3. Check for leaks using a liquid soap solution. If any leaks are detected, purge the nitrogen, repair the leak(s) and repeat the leak check procedure.

Leak checking of refrigerant line braze joints and evaporator unit using R454B refrigerant. (See Step 5b)

1. Connect R454B source to the service port of the liquid line service valve. Use of a manifold gauge set will facilitate connecting and disconnecting of the refrigerant source for leak checking. Pressurize refrigerant lines and indoor coil with refrigerant gas.
2. Leak check with an electronic leak detector or liquid soap solution. If any leaks are detected, use a refrigerant recovery system to remove the refrigerant. Repair the leak(s) and repeat the leak check procedure.

Step 5a:

Using a liquid soap solution

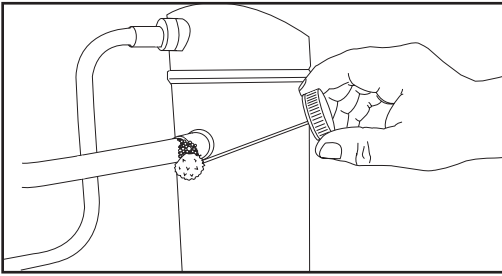

Apply liquid soap solution to check for leaks

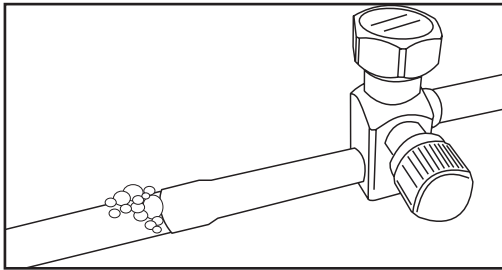

Bubbles forming in the liquid soap solution indicates a leak

1. Connect the vacuum pump to the service ports of the liquid line and vapor line service valves. If the vacuum pump lines do not contain shut-off valves, hook up the vacuum pump through a manifold gauge set, as the vacuum pump lines must be closed for step 4.

- a. If the evacuation is being performed on a new system installation, the heat pump service valves should be kept in the closed position. The vacuum pump will then be able to evacuate the refrigerant lines and evaporator coil.
 - b. If the evacuation is being performed on an installation where the heat pump factory charge has been lost, the service valves should be opened.

2. Following the vacuum pump manufacturer's instructions, allow the pump to operate until the system has been evacuated down to 300 microns.

Note: Check for leaks if unable to get to 300 microns.

3. Allow the pump to continue running an additional 15 minutes. Turn off the pump and leave connections secured. After 10 minutes if system fails to hold 500 microns or less, check all connections for tight fit and repeat evacuation procedure.

4. Isolate the vacuum pump by closing the shut-off valves on vacuum pump lines or test gauge manifold.

5. Open the service valves. Opening the service valves will allow the refrigerant in the heat pump to enter the refrigerant lines and evaporator coil. The vacuum pump can now be disconnected. (See Step 6 and 7)

Step 5b:

Using an electronic leak detector

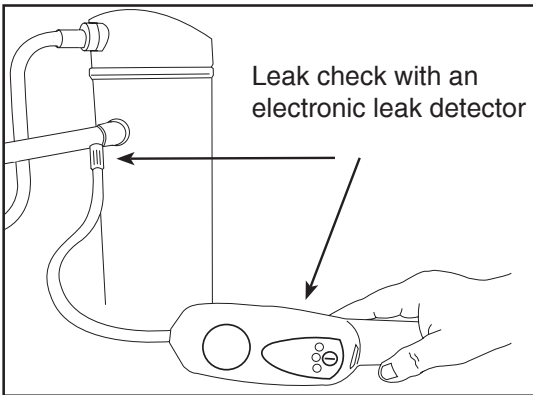

Leak check with an electronic leak detector

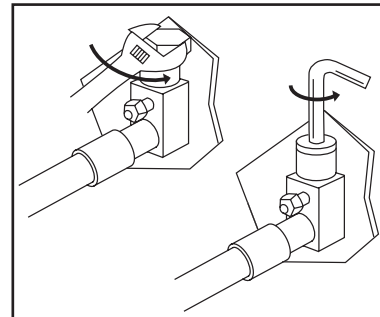

This is not a back seating valve. To open the valve remove the valve cap with an adjustable wrench. Insert a 3/16" or 5/16" hex wrench into the stem. Back out counter-clockwise until the valve stem just touches the retaining ring. CAUTION (Certain combination hex wrenches designed for service valves may not properly seat into the valve stem and may lead to stripping. Make sure the hex wrench is seated completely in the valve when first opening)

Evacuation

When evacuating refrigerant, charge shall be recovered into the correct recovery cylinders if venting is not allowed by local and national codes.

Step 7:

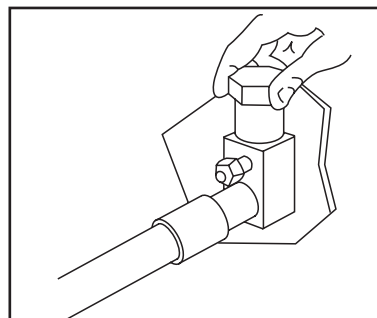

Replace the valve cap finger tight then tighten an additional 1/12 turn or 1/2 hex flat. A metal-to-metal seal is now complete. Complete normal factory recommended procedures.

Electrical Connections

Note: Make certain that the volts, hertz, and phase correspond to that specified on the unit rating plate, and that the service provided by the utility is sufficient to handle the additional load imposed by this equipment.

Make all electrical connections in accordance with the National Electrical Code and any pertinent local codes or ordinances. Use a separate branch electrical circuit for this unit. Locate a disconnecting means within sight of and readily accessible to the unit.

- a. Line Voltage Connections
- b. Connect the single phase power supply to unit contactor terminal L1 and L2
- c. Connect ground wire to lug
- d. Low Voltage Connections

Consult the indoor unit installation instructions for thermostat connections. **Use a 5-wire thermostat cable between the units.**

When locating the room thermostat, it should be in the natural circulating path of room air. Avoid locations where the thermostat would be exposed to cold air infiltration; drafts from windows, doors or other openings leading to the outside; exposure to air currents from warm-or-cold air registers or to exposure where the natural circulation of the air is cut off, such as behind doors, above or below mantels, shelves, etc.

Electrical - Low Voltage

Low Voltage Maximum Wire Length:

Table defines the maximum total length of low voltage wiring from the heat pump to the indoor unit and to the thermostat.

24 VOLTS	
WIRE SIZE	MAX. WIRE LENGTH
18 AWG	150 Ft.
16 AWG	225 Ft.
14 AWG	300 Ft.

Electrical - High Voltage

NOMINAL VOLTAGE	MINIMUM VOLTAGE	MAXIMUM VOLTAGE
208-230	196	244

High Voltage Power Supply

⚠ WARNING

LIVE ELECTRICAL COMPONENTS!

During installation, testing, servicing and troubleshooting of this product, it may be necessary to work with live electrical components. Failure to follow all electrical safety precautions when exposed to live electrical components could result in death or serious injury.

⚠ AVERTISSEMENT

COMPOSANTS ÉLECTRIQUES SOUS EN DIRECT!

Lors de l'installation, des tests, de l'entretien et du dépannage de ce produit, il peut être nécessaire de travailler avec des composants électriques en direct. Le non-respect de toutes les précautions de sécurité électrique pourrait entraîner des blessures graves ou la mort.

The high voltage power supply must agree with the equipment nameplate.
OR

Make certain that the volts, hertz, and phase correspond to that specified on the unit rating plate, and that the service provided by the utility is sufficient to handle the additional load imposed by this equipment.

Power wiring must comply with national, state, and local codes.

Follow instructions on unit wiring diagram located on the inside of the access door, or cabinet and in the wiring diagrams included with the unit.

Install a separate disconnect switch at the location of the through the wall unit.

Ground the unit per national, state, and local code requirements.

Disconnect Switch

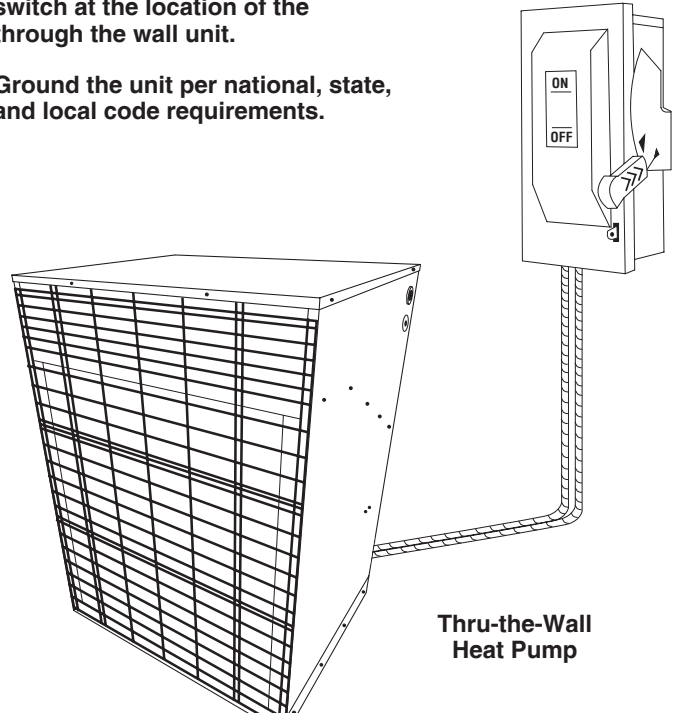

Thru-the-Wall Heat Pump

Start Up

1. Ensure that directions on page 6 through 10 have been completed. Check numbers once done.
2. Turn on disconnect(s) to apply power to all equipment.
3. Wait one (1) hour before starting the unit if compressor crankcase heater accessory is used and the Outdoor Ambient is below 70°.
4. Set system thermostat to ON.

Sequence of Operations

On a “call for cooling”, the thermostat “makes” circuits R-O, R-G, and R-Y. Circuit R-G energizes the indoor blower motor relay. Circuit R-O energizes the reversing valve. Circuit R-Y energizes the contactor starting the compressor and outdoor fan.

When the thermostat is satisfied, the contacts open, de-energizing the indoor blower relay, contactor, and reversing valve. The indoor and outdoor fans and compressor will stop.

On a “call for heating”, the room heat pump thermostat “makes” circuits R-G and R-Y. Circuit R-G energizes the indoor blower motor relay. Circuit R-Y energizes the contactor starting the compressor and outdoor fan. The reversing valve will not be energized and the system will be in the heating mode. When the room heat pump thermostat is satisfied, the contacts open, de-energizing the indoor blower relay and contactor. The indoor and outdoor fans and compressor will stop. When the indoor thermostat is calling for heat (24 VAC signal at the Y terminal), the defrost board begins monitoring for a temperature differential value between OAT (outdoor air thermistor) and OCT (outdoor coil thermistor) to determine when to initiate a defrost. Each heat pump model may require a different defrost curve setting that can be adjusted using the dip switches on the board. Refer to page 16 to select the correct defrost curve for your unit. Once the board calls for a defrost, the time inhibitor will activate preventing another defrost for 30 minutes. The defrost board will initiate a timed defrost every 4 hours, whether or not the OAT and OCT reach their curves. This timed defrost will occur only while the system is running in heating mode. During a demand defrost cycle, the board will shut down the condenser fan by opening the NC and C terminals on the CFM relay and will energize the reversing valve via the O terminal. The defrost cycle will terminate when the OCT temperature satisfies before 10 minutes expires. When the defrost cycle terminates the board will de-energize the reversing valve and close the NC and C terminal to the CFM relay.

If the outdoor temperature is cold enough to produce icing on the outdoor coil during the heating mode (approximately 34°), the condensate heater will be energized through the heater thermostat located in the control box. This heater stays energized during cold weather to keep any defrosted water from refreezing in the pan. The condensate pan under the coil must be piped per item number 12 under the “Unit Location Considerations” section of this manual.

System Charge Adjustment

Temperature Measurements

Check that the outdoor temperature is 65°F or higher before adjusting charge based on subcooling. Subcooling (in cooling mode) is the only recommended method of charging the system. For reference, use the charge chart on the next page and refer to page 24 for your systems proper subcooling value. For best results the indoor temperature should be kept between 70° F to 80° F.

Stabilize the system by operating for a minimum of 20 minutes. At startup, or whenever charge is removed or added, the system must be operated for a minimum of 20 minutes to stabilize before accurate measurements can be made.

For DOE or AHRI listed air handlers that are not NAH-MF series models please consult the factory for proper superheat and subcooling values as they may be different than the values published in these instructions. Certain combinations may also require the use of a crankcase heater.

Refrigerant Charging

This heat pump is factory charged with 3.75 lbs of R454B. The installer must add charge to meet the required subcooling value provided on page 24. Ensure contamination of different refrigerants does NOT occur when using charging equipment.

If the heat pump charge was lost for any reason, add factory refrigerant charge listed on heat pump data plate plus adjustments describe above to meet the required subcool as instructed on page 24. If the unit is operating during charge adjustment, the access panel must be in place to prevent high head pressure which would shut down the unit.

Note: For any length of linesets, the charge MUST be adjusted to meet the required subcool and superheat values as instructed on page 24 for both heating and cooling operation.

When replacing a R-22 or R-410A system, it is recommended, that new Line Sets be used. If the old line sets are to be used, they MUST be flushed with a commercial flushing agent. Hoses and lines shall be as short as possible. R454B refrigerant is not compatible with mineral oil.

IMPORTANT: The heat pump comes with minimum allowable charge as per safety regulation for shipping and storage purposes. When Installing a heat pump unit with a matched air-handler, system charge and TXV settings **MUST** be adjusted to meet the required subcool and superheat values as instructed on page 24 for both heating and cooling operation.

The heat pump can **ONLY** be installed with listed model of indoor unit to comply with DOE regulations. With any other indoor unit that is not listed in this manual will require factory testing and certification with DOE. Be sure both service valves are closed during tubing installation and leak checked to avoid loss of charge. A bi-flow liquid line filter drier must be installed.

NATIONAL COMFORT PRODUCTS R-454B CHARGING CHART																									
(Cooling)												(Heating)													
Subcooling (°F)	8	9	10	11	12	13	14	15	16	17	18	19	20	Subcooling (°F)	10	11	12	13	14	15	16	17	18	19	20
Liquid Pressure at Service Valve (psig)	R-454B Required Liquid Line Temperature °F												Liquid Pressure at Service Valve (psig)	R-454B Required Liquid Line Temperature °F											
249	78	77	76	75	74	73	72	71	70	69	68	67	66	202	62	61	60	59	58	57	56	55	54	53	52
252	79	78	77	76	75	74	73	72	71	70	69	68	67	205	63	62	61	60	59	58	57	56	55	54	53
256	80	79	78	77	76	75	74	73	72	71	70	69	68	208	64	63	62	61	60	59	58	57	56	55	54
260	81	80	79	78	77	76	75	74	73	72	71	70	69	211	65	64	63	62	61	60	59	58	57	56	55
263	82	81	80	79	78	77	76	75	74	73	72	71	70	215	66	65	64	63	62	61	60	59	58	57	56
267	83	82	81	80	79	78	77	76	75	74	73	72	71	218	67	66	65	64	63	62	61	60	59	58	57
271	84	83	82	81	80	79	78	77	76	75	74	73	72	221	68	67	66	65	64	63	62	61	60	59	58
275	85	84	83	82	81	80	79	78	77	76	75	74	73	224	69	68	67	66	65	64	63	62	61	60	59
279	86	85	84	83	82	81	80	79	78	77	76	75	74	228	70	69	68	67	66	65	64	63	62	61	60
283	87	86	85	84	83	82	81	80	79	78	77	76	75	231	71	70	69	68	67	66	65	64	63	62	61
287	88	87	86	85	84	83	82	81	80	79	78	77	76	235	72	71	70	69	68	67	66	65	64	63	62
291	89	88	87	86	85	84	83	82	81	80	79	78	77	238	73	72	71	70	69	68	67	66	65	64	63
295	90	89	88	87	86	85	84	83	82	81	80	79	78	242	74	73	72	71	70	69	68	67	66	65	64
299	91	90	89	88	87	86	85	84	83	82	81	80	79	245	75	74	73	72	71	70	69	68	67	66	65
303	92	91	90	89	88	87	86	85	84	83	82	81	80	249	76	75	74	73	72	71	70	69	68	67	66
307	93	92	91	90	89	88	87	86	85	84	83	82	81	252	77	76	75	74	73	72	71	70	69	68	67
311	94	93	92	91	90	89	88	87	86	85	84	83	82	256	78	77	76	75	74	73	72	71	70	69	68
315	95	94	93	92	91	90	89	88	87	86	85	84	83	260	79	78	77	76	75	74	73	72	71	70	69
320	96	95	94	93	92	91	90	89	88	87	86	85	84	263	80	79	78	77	76	75	74	73	72	71	70
324	97	96	95	94	93	92	91	90	89	88	87	86	85	267	81	80	79	78	77	76	75	74	73	72	71
329	98	97	96	95	94	93	92	91	90	89	88	87	86	271	82	81	80	79	78	77	76	75	74	73	72
333	99	98	97	96	95	94	93	92	91	90	89	88	87	275	83	82	81	80	79	78	77	76	75	74	73
337	100	99	98	97	96	95	94	93	92	91	90	89	88	279	84	83	82	81	80	79	78	77	76	75	74
342	101	100	99	98	97	96	95	94	93	92	91	90	89	283	85	84	83	82	81	80	79	78	77	76	75
347	102	101	100	99	98	97	96	95	94	93	92	91	90	287	86	85	84	83	82	81	80	79	78	77	76
351	103	102	101	100	99	98	97	96	95	94	93	92	91	291	87	86	85	84	83	82	81	80	79	78	77
356	104	103	102	101	100	99	98	97	96	95	94	93	92	295	88	87	86	85	84	83	82	81	80	79	78
361	105	104	103	102	101	100	99	98	97	96	95	94	93	299	89	88	87	86	85	84	83	82	81	80	79
365	106	105	104	103	102	101	100	99	98	97	96	95	94	303	90	89	88	87	86	85	84	83	82	81	80
370	107	106	105	104	103	102	101	100	99	98	97	96	95	307	91	90	89	88	87	86	85	84	83	82	81
375	108	107	106	105	104	103	102	101	100	99	98	97	96	311	92	91	90	89	88	87	86	85	84	83	82
380	109	108	107	106	105	104	103	102	101	100	99	98	97	315	93	92	91	90	89	88	87	86	85	84	83
385	110	109	108	107	106	105	104	103	102	101	100	99	98	320	94	93	92	91	90	89	88	87	86	85	84
390	111	110	109	108	107	106	105	104	103	102	101	100	99	324	95	94	93	92	91	90	89	88	87	86	85
395	112	111	110	109	108	107	106	105	104	103	102	101	100	329	96	95	94	93	92	91	90	89	88	87	86
400	113	112	111	110	109	108	107	106	105	104	103	102	101	333	97	96	95	94	93	92	91	90	89	88	87
405	114	113	112	111	110	109	108	107	106	105	104	103	102	337	98	97	96	95	94	93	92	91	90	89	88
410	115	114	113	112	111	110	109	108	107	106	105	104	103	342	99	98	97	96	95	94	93	92	91	90	89
416	116	115	114	113	112	111	110	109	108	107	106	105	104	347	100	99	98	97	96	95	94	93	92	91	90
421	117	116	115	114	113	112	111	110	109	108	107	106	105	351	101	100	99	98	97	96	95	94	93	92	91
426	118	117	116	115	114	113	112	111	110	109	108	107	106	356	102	101	100	99	98	97	96	95	94	93	92
432	119	118	117	116	115	114	113	112	111	110	109	108	107	361	103	102	101	100	99	98	97	96	95	94	93
437	120	119	118	117	116	115	114	113	112	111	110	109	108	365	104	103	102	101	100	99	98	97	96	95	94
443	121	120	119	118	117	116	115	114	113	112	111	110	109	370	105	104	103	102	101	100	99	98	97	96	95
448	122	121	120	119	118	117	116	115	114	113	112	111	110	375	106	105	104	103	102	101	100	99	98	97	96
454	123	122	121	120	119	118	117	116	115	114	113	112	111	380	107	106	105	104	103	102	101	100	99	98	97
459	124	123	122	121	120	119	118	117	116	115	114	113	112	385	108	107	106	105	104	103	102	101	100	99	98
465	125	124	123	122	121	120	119	118	117	116	115	114	113	390	109	108	107	106	105	104	103	102	101	100	99
471	126	125	124	123	122	121	120	119	118	117	116	115	114	395	110	109	108	107	106	105	104	103	102	101	100
477	127	126	125	124	123	122	121	120	119	118	117	116	115	400	111	110	109	108	107	106	105	104	103	102	101

Installers Notes:

Cooling Mode

- Heat pump door must be in place while adjusting subcooling
- Ambient temperature must be between 65°F-95°F
- Indoor return air temperature must be above 70°F
- Allow 20 minutes of run time at premium conditions before adjusting charge
- Driving rain against the condenser coil can affect setting proper subcooling
- Add charge to increase subcooling
- Remove charge to decrease subcooling
- Indoor units must be equipped with a adjustable Thermal expansion valve (TXV) to meet the recommended superheat value provided on page # 24.

Heating Mode

- Heat pump door must be in place while adjusting subcooling
- Allow 20 minutes of run time at premium conditions before adjusting charge
- Add charge to increase subcooling
- Remove charge to decrease subcooling
- Indoor units must be equipped with a thermal expansion valve (TXV)

⚠ CAUTION

**Low Suction Pressure Operation!
Compressor Damage!**

Do not operate with a restricted suction. Do not operate with the lowpressure cut-out bridged. Do not operate compressor without enough system charge to maintain at least 0.5 bar (7.25 psi) suction pressure. **Allowing pressure to drop below 0.5 bar (7.25 psi) for more than a few seconds may overheat scrolls and cause early drive bearing damage.**

The system should be liquid-charged through the liquid-receiver shut-off valve or through a valve in the liquid line. The use of a filter drier in the charging line is highly recommended. R454B is a blend and scrolls have discharge check valves, systems should be liquid-charged on both high and low sides simultaneously to ensure a positive refrigerant pressure is present in the compressor before it runs. The majority of the charge should be placed in the high side of the system to prevent bearing washout during first-time start on the assembly line.

⚠ PRUDENCE

**Fonctionnement À Basse Pression D’aspiration!
Dommages Au Compresseur!**

Ne fonctionnez pas avec une aspiration restreinte. Ne fonctionnez pas avec la découpe à basse pression pontée. Ne pas faire fonctionner le compresseur sans suffisamment de charge du système pour maintenir une pression d’aspiration d’au moins 0,5 bar (7,25 psi). **Laisser la pression tomber en dessous de 0,5 bar (7,25 psi) pendant plus de quelques secondes peut surchauffer les rouleaux et causer des dommages précoces aux roulements d’entraînement.**

Le système doit être chargé de liquide par l’intermédiaire de la vanne d’arrêt du récepteur de liquide ou d’une vanne dans la conduite de liquide. L’utilisation d’un séchoir filtrant dans la ligne de charge est fortement recommandée. Étant donné que R454B est un mélange et que les rouleaux ont des clapets anti-retour de décharge, les systèmes doivent être chargés de liquide simultanément sur les côtés haut et bas pour s’assurer qu’une pression positive du réfrigérant est présente dans le compresseur avant qu’il ne fonctionne. La majeure partie de la charge devrait être placée dans le côté haut du système.

⚠ WARNING

The unit must be permanently grounded. **Failure to do so can cause electrical shock resulting in severe personal injury or death.**

⚠ AVERTISSEMENT

L’unité doit être mise à la terre en permanence. **Le défaut de le faire peut provoquer un choc électrique entraînant des blessures graves ou la mort.**

1. Charging cylinder shall be in an upright position, kept firmly on a flat and stable surface while charging.
2. Tighten the manifold gauge set charging connection. Open the main manifold gauge set valve and introduce refrigerant into the system.

Note: Oil charge is polyester 3MA POE.

CAUTION: It is very important that when charging a system to charge liquid refrigerant into the high side only. It is not good practice to flood liquid refrigerant from a refrigerant cylinder into the crankcase of the a stationary compressor through the suction line. If additional charge is required carefully charge liquid incrementally into the low side of the system with the compressor operating. Excessive liquid introduced into the suction line will damage the compressor.

3. Use extreme care to not overfill the refrigerating system. When the correct refrigerant charge level is obtained, remove the manifold gauge set.
4. Replace the gauge port caps.

Permanently stamp the unit data plate with the total amount of refrigerant in the system. For coils equipped with TXV’s charge to subcooling at evaporator inlet and adjust your TXV to match your superheat with the value as specified on page 24. Always use the true suction port located on the suction line entering the compressor to measure superheat.

Permanently stamp the field charging label (found next to nameplate) with the amount of refrigerant added and the total amount of refrigerant in the system.

It is recommended to return to the site in both seasons to assure the system is charged properly.

Total Charge Guide (oz.)									
Outdoor Model	10	15	20	25	30	35	40	45	50
NHP5183000	80	82	84	86	88	90	92	94	96
NHP5243000	80	82	84	86	88	90	92	94	96
NHP5185000	90	92	94	96	98	100	102	104	106
NHP5245000	83	85	87	89	91	93	95	97	99
NHP5305000	93	95	97	99	101	103	105	107	109

Units factory charged with 60 oz. of R454B.
 Estimated **total** refrigerant charge (oz.) based on lineset length (ft.)
 These values will vary depending on the indoor unit, follow installation guide for proper charging requirements.

Note: All information based on the following Air Flow Chart. Required superheat varies for each system. Refer to page 24 for recommended superheat. Superheat temperature measurements should be taken within 3 feet of the compressor suction line connection. Use the true suction port provided on the suction line for superheat measurements.

Air Flow Chart

3000 Series

Outdoor Model	Indoor Model	Motor Speed Color (Tap)	Static (in. wc.)	Airflow (SCFM) ^{1,2}
NHP5183000A-**-**	NAH524MFA-**-**	Black (2)	0.3	580
NHP5243000A-**-**	NAH524MFA-**-**	Blue (3)	0.3	770

5000 Series

Outdoor Model	Indoor Model	Motor Speed Color (Tap)	Static (in. wc.)	Airflow (SCFM) ^{1,2}
NHP5185000A-**-**	NAH524MFA-**-**	Black (2)	0.3	580
NHP5245000A-**-**	NAH524MFA-**-**	Blue (3)	0.3	770
NHP5305000A-**-**	NAH530MFA-**-**	Yellow (4)	0.3	890

1. Airflow is determined with a filter at wet coil conditions. The airflow in the table above is recommended for best system performance
2. The airflow values may vary when the system is running in heating mode

For DOE or AHRI listed air handlers that are not NAH-MF series models please consult the factory for proper settings and airflow values as they will be different than the values published in these instructions.

If charging the system in heating mode please use the following chart as a guideline only.

For DOE or AHRI listed air handlers that are not NAH-MF series models please consult the factory for proper superheat and subcooling values as they may be different than the values published in these instructions. Certain combinations may also require the use of a crankcase heater.

NHP5183000A-**-**

OD Ambient	47°F	35°F	17°F
"Heating Capacity (Btu/h)"	15,800	12,500	9,900
Delta T (°F)	26.1	19.7	16.2
AMPS	6.4	6.3	6.0
High Pressure (psig)	299.4	269.0	254.6
Low Pressure (psig)	92.8	70.4	55.0
Subcooling (°F)*	13.5	5.3	7.5
Superheat (°F)+	9.0	3.0	2.0

NHP5243000A-**-**

OD Ambient	47°F	35°F	17°F
"Heating Capacity (Btu/h)"	19,500	15,300	11,800
Delta T (°F)	24	19.5	14.7
AMPS	7.8	7.5	7.4
High Pressure (psig)	291	272	249
Low Pressure (psig)	88.9	74.7	51.7
Subcooling (°F)*	11.7	3.0	2.8
Superheat (°F)+	9.0	3.0	1.0

NHP5185000A-**-**

OD Ambient	47°F	35°F	17°F
"Heating Capacity (Btu/h)"	16,000	12,900	9,900
Delta T (°F)	27.5	22.4	17.1
AMPS	7.2	6.9	7.1
High Pressure (psig)	310.0	288.0	262.5
Low Pressure (psig)	96.3	77.5	54.3
Subcooling (°F)*	18.0	16.1	17.0
Superheat (°F)+	9.0	8.0	9.8

NHP5245000A-**-**

OD Ambient	47°F	35°F	17°F
"Heating Capacity (Btu/h)"	21,000	17,200	12,400
Delta T (°F)	27.2	22.9	17.46
AMPS	9.1	8.7	8.4
High Pressure (psig)	304.7	286.5	260.3
Low Pressure (psig)	89.6	74.8	52.0
Subcooling (°F)*	14.3	11.7	12.1
Superheat (°F)+	8.5	6.1	5.2

NHP5305000A-**-**

OD Ambient	47°F	35°F	17°F
"Heating Capacity (Btu/h)"	23,000	18,900	13,200
Delta T (°F)	24.4	20.3	15.3
AMPS	9.8	9.4	9.1
High Pressure (psig)	300.9	282.8	260.9
Low Pressure (psig)	83.3	68.9	45.6
Subcooling (°F)*	19.3	15.4	17.0
Superheat (°F)+	11.6	8.3	13.5

* Subcooling measured at service valve during heating mode
+ Superheat measured at compressor

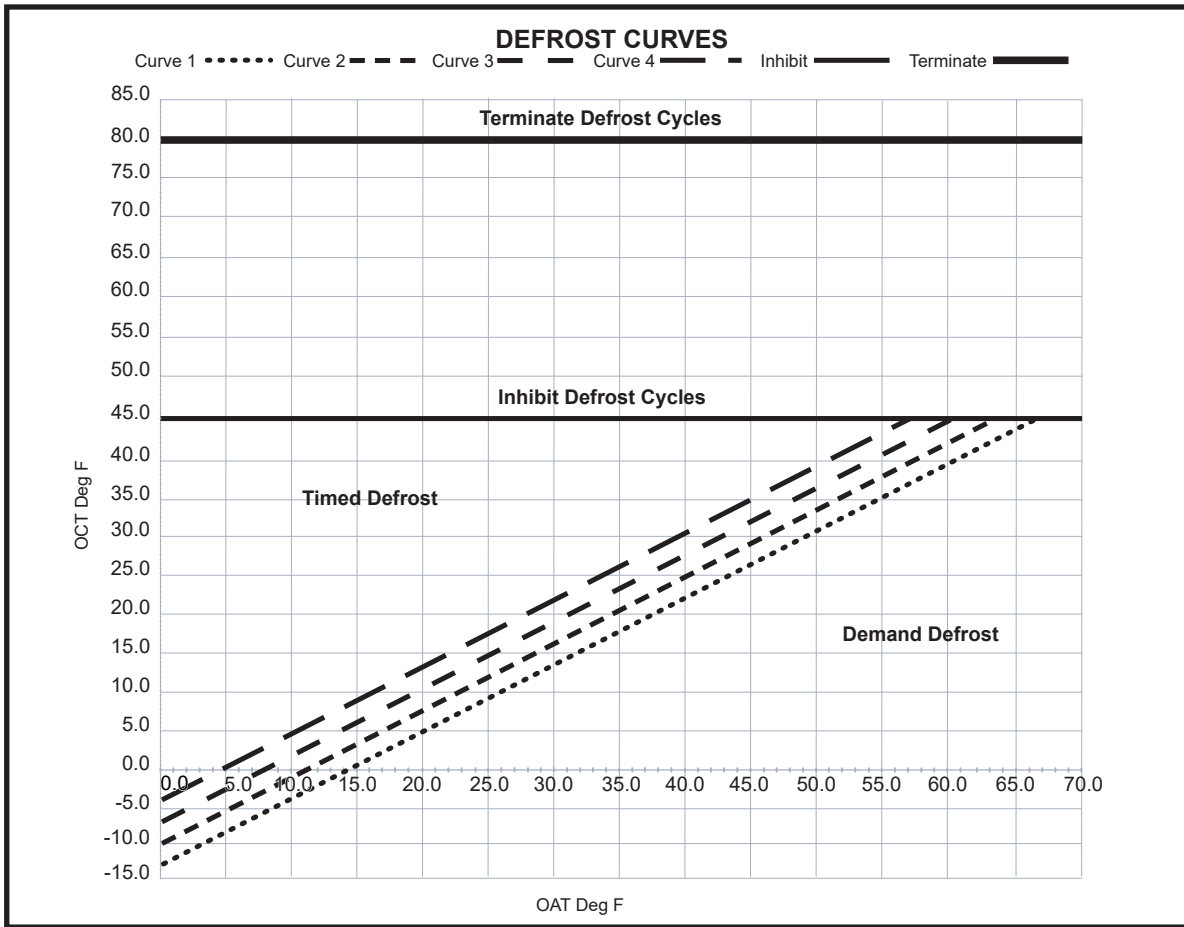

Demand Defrost Setting	
3000 Series	
Outdoor Model	Defrost Curve Setting ¹
NHP5183000A-**	3
NHP5243000A-**	2
5000 Series	
NHP5185000A-**	3
NHP5245000A-**	2
NHP5305000A-**	2

Dip Switch setting On Defrost Board		
Defrost Curve	Dip Switch 1	Dip Switch 2
1	Off	Off
2	On	Off
3	Off	On
4	On	On

1. Demand defrost curve setting is determined based on 35°F OD Ambient test

The demand defrost curve setting is important for system performance and equipment protection. During heating operation, the outdoor coil accumulates frost. Each system can accumulate frost on the outdoor coil at different rates. It is **NECESSARY** for the installer to check that the appropriate recommended defrost curve is selected for your system. For defrost curve adjustments refer to the dip switch table above to make necessary changes. A defrost test can be initiated by pressing the button provided on the defrost control board. Once the button is pressed the system will go into a 60 second timed defrost.

Note: Adjustment of the defrost curve may be necessary to provide complete defrost for your climate zone. Refer to the defrost curve plot above to select the appropriate defrost settings for your climate zone.

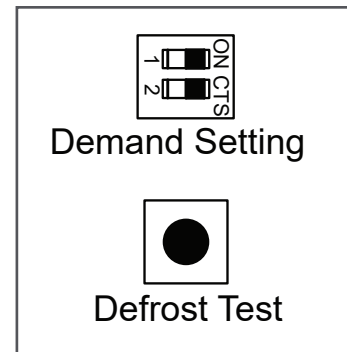

Maintenance

At all times, NCP maintenance and service guidelines shall be followed. If in doubt, consult NCP's technical department for assistance.

The following safety checks must be performed prior to conducting work on the system to minimize the risk of ignition of the refrigerant:

1. Work shall be undertaken under a controlled procedure so as to minimize the risk of a flammable gas or vapor being present while the work is being performed.
2. All maintenance staff and others working in the local area shall be instructed on the nature of work being carried out. Work in confined spaces shall be avoided.
3. The area shall be checked with an appropriate refrigerant detector prior to and during work, to ensure the technician is aware of potentially toxic or flammable atmospheres. Ensure that the leak detection equipment being used is suitable for use with all applicable refrigerants, i.e. non-sparking, adequately sealed or intrinsically safe.
4. If any hot work is to be conducted on the refrigerating equipment or any associated parts, appropriate fire extinguishing equipment shall be available to hand. Have a dry powder or CO2 fire extinguisher adjacent to the charging area.
5. No person carrying out work in relation to a REFRIGERATING SYSTEM which involves exposing any pipe work shall use any sources of ignition in such a manner that it may lead to the risk of fire or explosion. All possible ignition sources, including cigarette smoking, should be kept sufficiently far away from the site of installation, repairing, removing and disposal, during which refrigerant can possibly be released to the surrounding space. Prior to work taking place, the area around the equipment is to be surveyed to make sure that there are no flammable hazards or ignition risks. "No Smoking" signs shall be displayed.
6. Ensure that the area is in the open or that it is adequately ventilated before breaking into the system or conducting any hot work. A degree of ventilation shall continue during the period that the work is carried out. The ventilation should safely disperse any released refrigerant and preferably expel it externally into the atmosphere.
7. The following safety checks must be performed prior to conducting work on the refrigerating equipment
 - a. the actual REFRIGERANT CHARGE is in accordance with the room size within which the refrigerant containing parts are installed.
 - b. the ventilation machinery and outlets are operating adequately and are not obstructed.
 - c. Marking to the equipment continues to be visible and legible. Markings and signs that are illegible shall be corrected or replaced.
 - d. refrigerating pipe or components are installed in a position where they are unlikely to be exposed to any substance which may corrode refrigerant containing components, unless the components are constructed of materials which are inherently resistant to being corroded or are suitably protected against being so corroded.

8. The following safety checks must be performed prior to conducting electrical work on the system to minimize the risk of ignition and electrocution.

- a. Capacitors are discharged: this shall be done in a safe manner to avoid possibility of sparking.
 - b. No live electrical components and wiring are exposed while charging, recovering or purging the system.
 - c. Ensure there is continuity of earth bonding.
9. Annually clean the inside of the unit to keep the weep holes in the base pan open to assure proper drainage of water from the unit.
10. Keep the condenser coil clean and free of anything that restricts free air flow. For sea coast applications the condenser coil should be washed periodically to remove salt accumulation.
11. Reduced indoor air flow through a duct system will cause the indoor coil to ice up in cooling. If this condition is not corrected, premature system failure will result. Indoor air filters should be cleaned and changed regularly.
12. Annually check units mounting to structure to ensure integrity. Seal between cabinet and/or sleeve for air or water leakage. Check exposed surfaces for corrosion. Replace or paint parts as required. This maintenance is critical to prevent stains and damage to exterior surface of building.
13. Inspect refrigerant piping for leaks and suction line insulation for deterioration and damage. Improper insulation can cause condensate water damage.
14. Pressure and temperature readings of the high and low sides of the system should be checked for proper superheat and/or subcooling. Correct if required. See System Charge Adjustment on page 14.
15. Check motor amperage to nameplate value, inspect the motor mounting and prop fan hub for tightness and rust or corrosion. Observe the prop fan blade for balance.
16. Inspect the wire connections and contactor dry contacts for evidence of arcing, over heating, or deterioration. Inspect wires are not subject to wear, corrosion, excessive pressure, vibration, sharp edges or any other adverse environmental effects. Take into account the effects of aging or continual vibration from sources such as compressors or fans.
17. Sealed electrical components shall be replaced.
18. Intrinsically safe components must be replaced.

Decommissioning/Recovery

Note: Before carrying out this procedure, it is essential that the technician is completely familiar with the equipment and all its detail. It is recommended good practice that all refrigerants are recovered safely. Prior to the task being carried out, an oil and refrigerant sample shall be taken in case analysis is required prior to re-use of recovered refrigerant. It is essential that electrical power is available before the task is commenced.

1. Become familiar with the equipment and its operation.
2. Isolate system electrically.
3. Before attempting the procedure, ensure that:
 - a. mechanical handling equipment is available, if required, for handling refrigerant cylinders;
 - b. all personal protective equipment is available and being used correctly;
 - c. the recovery process is supervised at all times by a competent person;
 - d. recovery equipment and cylinders conform to the appropriate standards.

Note: When transferring refrigerant into cylinders, ensure that only appropriate refrigerant recovery cylinders are employed. Recovery equipment shall be in good working order with a set of instructions concerning the equipment that is at hand and shall be suitable for the recovery of the flammable refrigerant. Ensure that the correct number of cylinders for holding the total system charge is available. All cylinders to be used are designated for the recovered refrigerant and labelled for that refrigerant (i.e. special cylinders for the recovery of refrigerant). Cylinders shall be complete with pressure-relief valve and associated shut-off valves in good working order. Empty recovery cylinders are evacuated and, if possible, cooled before recovery occurs. In addition, a set of calibrated weighing scales shall be available and in good working order. Hoses shall be complete with leak-free disconnect couplings and in good condition.

4. Pump down refrigerant system
5. Make sure that cylinder is situated on the scales before recovery takes place.
6. Start the recovery machine and operate in accordance with instructions
7. Do not overfill cylinders (no more than 80% volume liquid charge).
8. Do not exceed the maximum working pressure of the cylinder, even temporarily.
9. When the cylinders have been filled correctly and the process completed, make sure that the cylinders and the equipment are removed from site promptly and all isolation valves on the equipment are closed off.
10. Recovered refrigerant shall not be charged into another **REFRIGERATING SYSTEM** unless it has been cleaned and checked. Recovered refrigerant shall be processed according to local legislation in the correct recovery cylinder, and the relevant waste transfer note arranged. Do not mix refrigerants in recovery units and especially not in cylinders
11. If compressors or compressor oils are to be removed, ensure that they have been evacuated to an acceptable level to make certain that flammable refrigerant does not remain within the lubricant. The compressor body shall not be heated by an open flame or other ignition sources to accelerate this process. When oil is drained from a system, it shall be carried out safely

Equipment shall be labelled stating that it has been de-commissioned and emptied of refrigerant. The label shall be dated and signed. Label shall state the equipment contains **FLAMMABLE REFRIGERANT**.

Checkout Procedures and Troubleshooting

Checkout Procedures	
After installation has been completed, it is recommended that the system be checked against the following list:	
1. Leak check refrigerant lines.	<input type="checkbox"/>
2. Properly insulate suction lines and fittings.	<input type="checkbox"/>
3. Properly secure and isolate all refrigerant lines.	<input type="checkbox"/>
4. Seal passages through masonry. If mortar is used, prevent mortar from coming into direct contact with copper tubing.	<input type="checkbox"/>
5. Verify that all electrical connections are tight.	<input type="checkbox"/>
6. Observe outdoor fan during on cycle for clearance and smooth operation.	<input type="checkbox"/>
7. Be sure the indoor condensate line drains freely. Pour water into drain pan.	<input type="checkbox"/>
8. Be sure that supply registers and return grilles are open and unobstructed.	<input type="checkbox"/>
9. Be sure that a return air filter is installed.	<input type="checkbox"/>
10. Be sure that the correct indoor airflow setting is used.	<input type="checkbox"/>
11. Operate complete system in each mode to ensure safe operation.	<input type="checkbox"/>
12. Be sure that the system is not left undercharged or overcharged. Measure your subcool at condenser liquid valve and make sure that it matches with factory recommended subcool value provide on page 24.	<input type="checkbox"/>
13. Be sure that indoor unit TXV is providing required superheat. Measure superheat at compressor suction port and make sure it matches with factory recommended superheat value provided on page 24	<input type="checkbox"/>

Service Access

Note: 30" of clearance is required for service accessibility on the inside. All units are serviceable from the inside.

Noise

We design our unit as quiet as possible; please keep in mind when locating the unit that it does make noise. Use common precautions as you would for other mechanical appliances pertaining to noise.

Outdoor Sound: 79.8 dBA (AHRI Standard 270-2008)

Sound Cover

As an option, we offer an **Insulated Sound Cover** for installation over the inside cover of the unit.

Indoor Sound

Without Insulated Sound Cover: 70.4 dBA

With Insulated Sound Cover: 68.3 dBA

(AHRI Standard 350-2008)

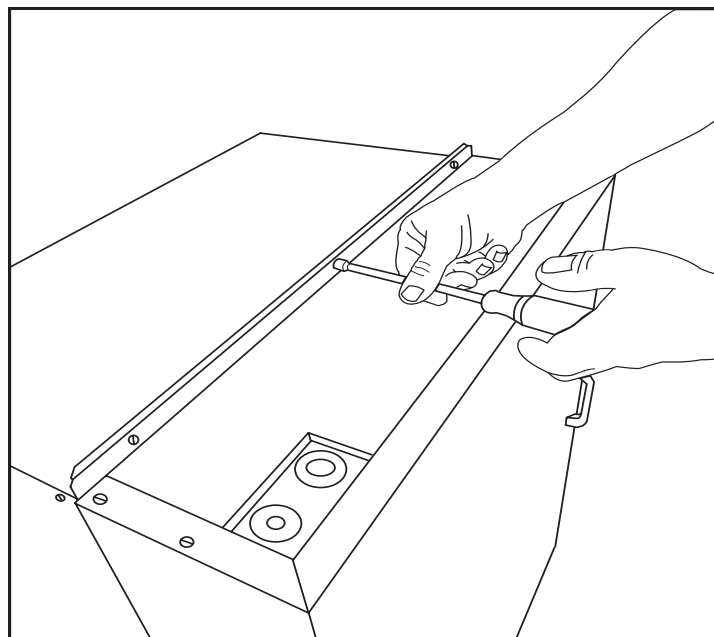

The Insulated Sound Cover will be supplied with insulated handles installed and assembled.

To install onto the unit, either the top or bottom will need to be removed depending on the exit point of the tubing. (3 screws)

Sound Covers Available

3000 I.D. Cover

5000 I.D. Cover

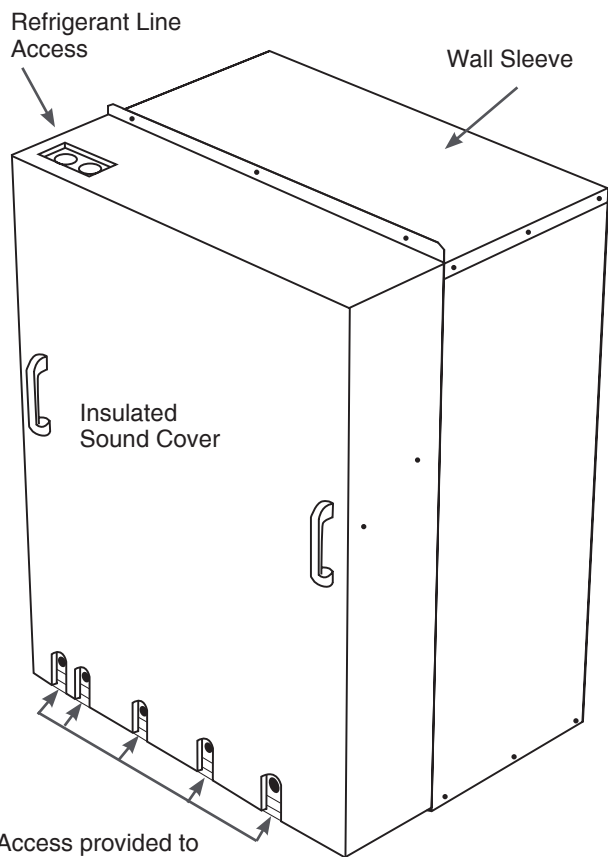

Access provided to
Line Set Connections,
Line Voltage, Low Voltage
and Refrigerant Line
Access



IMPORTANT!!!

BEFORE REMOVING A WARRANTY COMPRESSOR, PLEASE FILL OUT THE FOLLOWING AND CALL (800) 523-7138.

REMOVAL OF COMPRESSOR WITHOUT FACTORY VERIFICATION CAN LEAD TO WARRANTY CREDIT BEING DENIED

1. Incoming Voltage to Compressor at Contactor is: _____ Volts \sim AC
2. Compressor Starting AMP Draw: _____ A
3. Compressor Winding OHM Reading between Terminals C & S: _____ Ω
4. Compressor Winding OHM Reading between Terminals C & R: _____ Ω
5. Compressor Winding OHM Reading between Terminals R & S: _____ Ω
6. Compressor Winding OHM Reading between Terminals C & Ground: _____ Ω
7. Compressor Winding OHM Reading between Terminals R & Ground: _____ Ω
8. Compressor Winding OHM Reading between Terminals S & Ground: _____ Ω

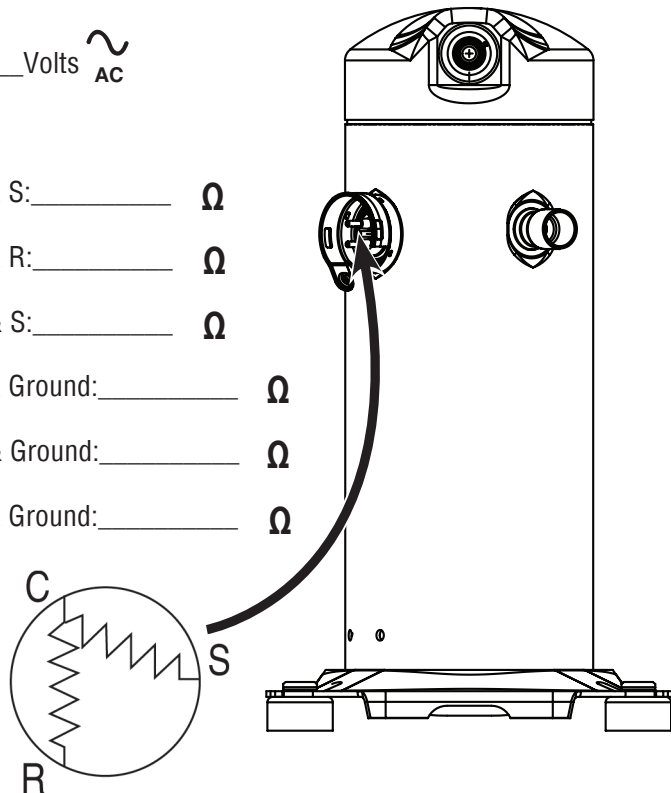

9. Run Capacitor Reading from HERM to COM: _____ μ F
10. Start Capacitor Reading if Used: _____ μ F

TOP VIEW OF CAPACITOR

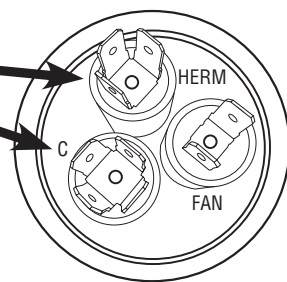

11. If the Compressor is Operating Please Indicate the Following:

Suction Pressure: _____ psig Discharge Pressure _____ psig

Super Heat: _____ F Subcooling: _____ F

208-230 VAC NOMINAL VOLTAGE
 196 VAC MINIMUM VOLTAGE
 244 VAC MAXIMUM VOLTAGE

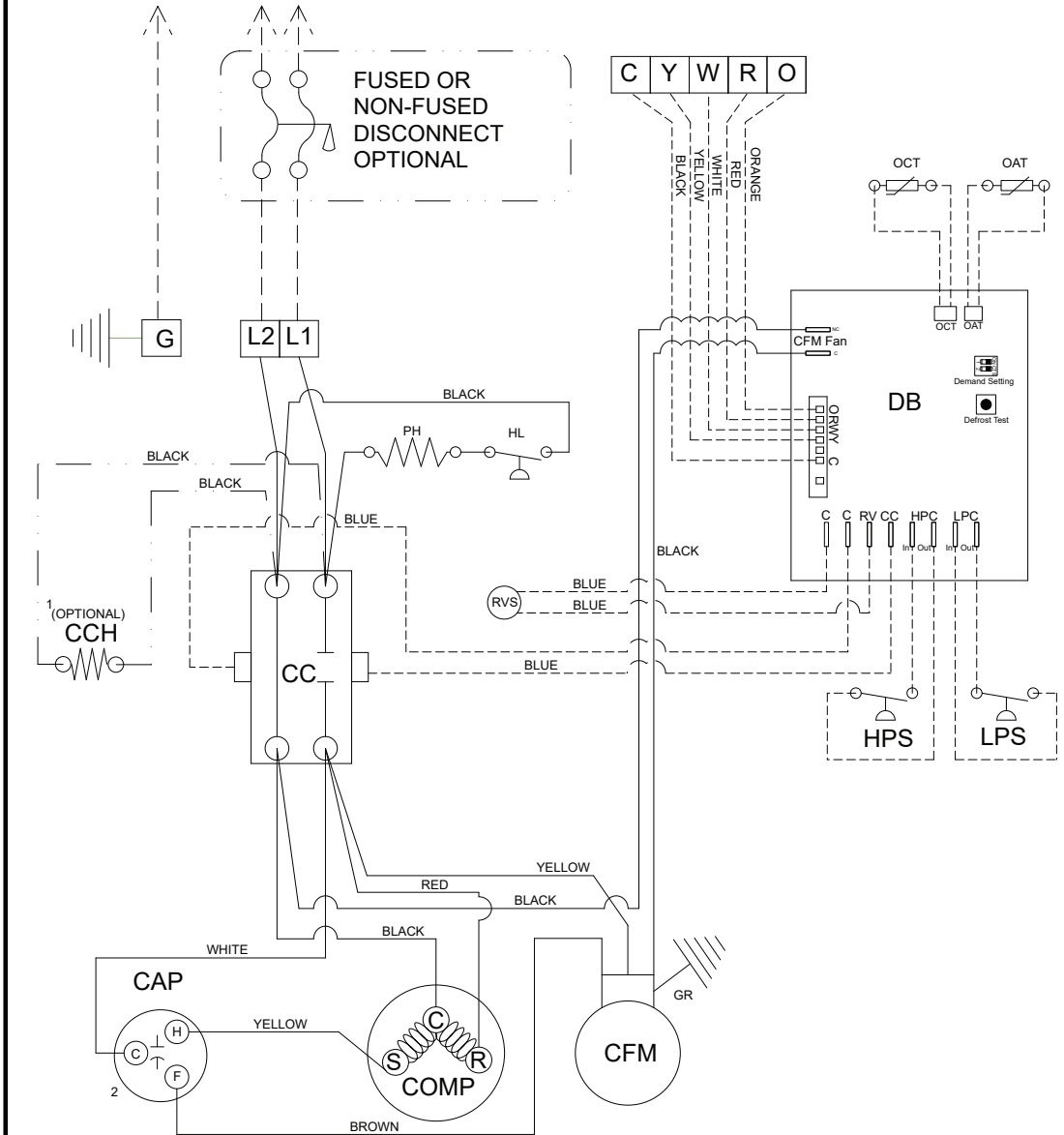

NOTE:
 1. Crankcase heater is available as a factory installed option.
 2. Certain units utilize CFM's that do not require a capacitor. This BROWN wire will not be included and a single capacitor will be used for the COMP.

LEGEND
 CAP - DUAL CAPACITOR
 CC - COMPRESSOR CONTACTOR
 CCH - CRANKCASE HEATER (OPTIONAL)
 COMP - COMPRESSOR
 CFM - CONDENSER FAN MOTOR
 DB - DEFROST BOARD
 HL - HIGH LIMIT
 HPS - HIGH PRESSURE SWITCH
 LPS - LOW PRESSURE SWITCH
 OAT - OUTDOOR AIR TEMP. SENSOR
 OCT - OUTDOOR COIL TEMP. SENSOR
 PH - PAN HEATER
 RVS - REVERSING VALVE SOLENOID

NATIONAL COMFORT PRODUCTS

539 DUNKSFERRY RD.
 Bensalem, Pa. 19020
 Phone: 800-523-7138
 FAX: 215-639-1674

**WIRING DIAGRAM
 NHP SERIES
 3000 & 5000**

DRAWN BY	DATE	JOB NUMBER
BS	8/18/2023	14299227 rev 1

3000 Series w/matches up to 12.5 SEER2*					
All Units 208/230-1-60Hz					
Model	Shipping Weight (lbs)	Compressor		MCA	MOP
		RLA	LRA		
NHP5183000A-**	167	7.2	47	10.3	15
NHP5243000A-**	167	9.2	59	12.8	20
Cond. Fan Motor Specs		1/4 HP, 1600 RPM, 1.3 FLA			
Condenser Coil Specs		3.43 ft2 Face Area, 16 FPI			
Dimensions		24 1/8" W x 32" H x 18 1/2" D			
Liquid Valve		3/8"	Suction Valve		3/4"

*When matched with NAH5**MF Air Handlers

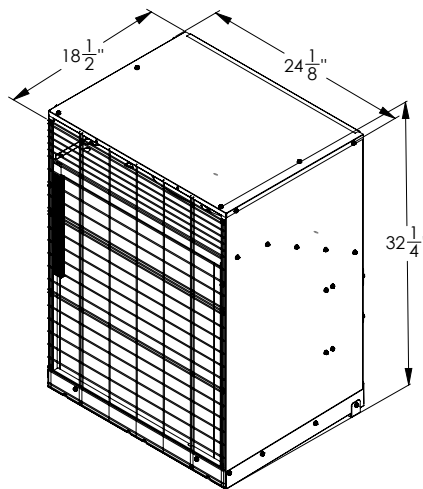
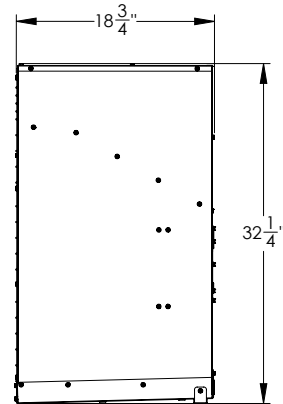
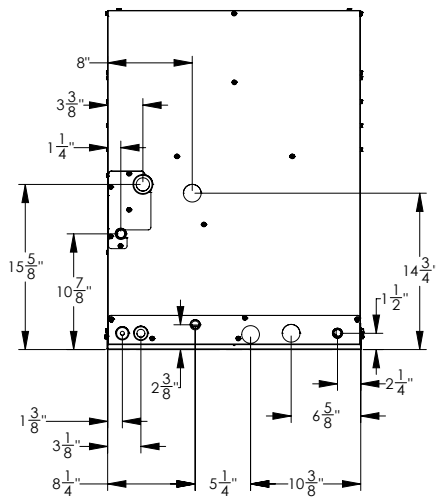
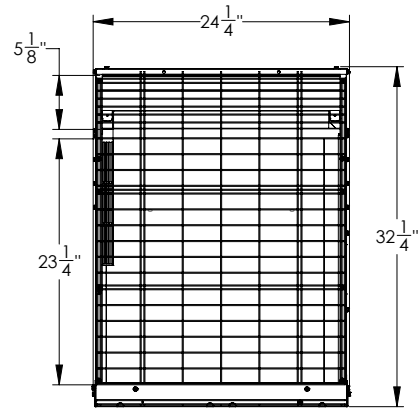

Note: Some dimensions that are shown in these drawings are measured between the edges of screw heads.

5000 Series w/ matches up to 13.5 SEER2*					
All Units 208/230-1-60Hz					
Model	Shipping weight (lbs)	Compressor		MCA	MOP
		RLA	LRA		
NHP5185000A-**-	187	7.2	47	11.0	15
NHP5245000A-**-	197	9.0	63	13.2	20
NHP5305000A-**-	202	10.4	71	15.1	25
Cond. Fan Motor		1/5 HP, 1650 RPM, 1.8 FLA			
Condenser Coil Specs		4.49 ft2 Face Area, 16 FPI			
Dimensions		26 7/8" W x 38 7/8" H x 18 1/2" D			
Liquid Valve		3/8"	Suction Valve	3/4"	

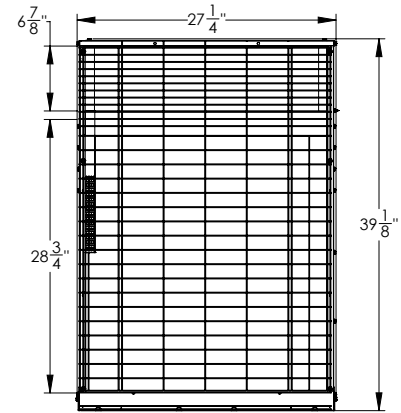

*When matched with NAH5**MF Air Handlers

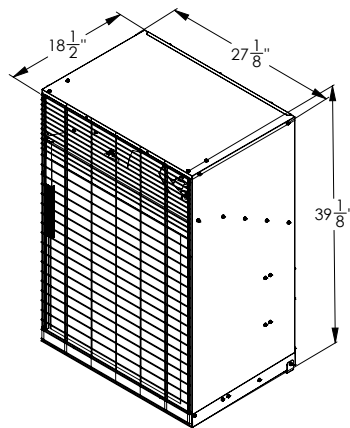
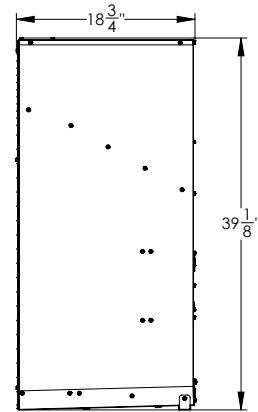
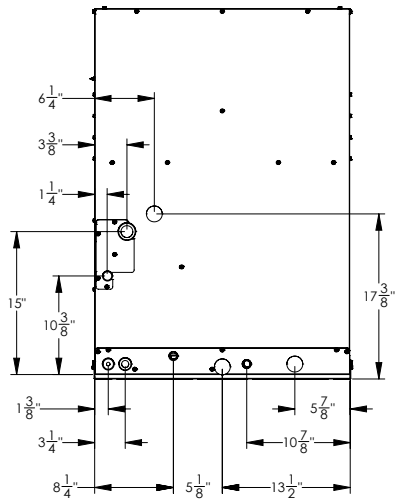

Note: Some dimensions that are shown in these drawings are measured between the edges of screw heads.

When installing the unit, the refrigerant charge must be adjusted to meet the subcool requirement in heating mode.

The indoor unit TXV must be adjusted to meet the required superheat in cooling mode.

The outdoor unit TXV must be adjusted to meet the required superheat in heating mode.

NHP Thru the Wall Heat Pumps matched with Air Handler - Cooling Data

Outdoor Model	Indoor Model	Indoor Model Speed	Rated Capacity (Btu/h)	Rated EER ² ₁	Nominal Airflow ² (SCFM)	SEER ² ₃	Liquid Subcool ⁴ (°F)	Suction Superheat ^{5,6} (°F)
NHP5183000A-**-**	NAH524MFA-**-**	Black (2)	17,800	11.4	580	12.5	12-16	11-15
NHP5243000A-**-**	NAH524MFA-**-**	Blue (3)	22,400	10.7	770	12.5	15-19	11-15
NHP5185000A-**-**	NAH524MFA-**-**	Black (2)	17,800	11.9	580	13.5	11-15	14-18
NHP5245000A-**-**	NAH524MFA-**-**	Blue (3)	23,800	11.6	770	13.5	7-11	12-16
NHP5305000A-**-**	NAH530MFA-**-**	Yellow (4)	26,800	11.3	890	13.0	13-17	12-16

1. EER₂ is determined based on the Evaporator match listed in this table
2. Airflow values are determined at wet coil conditions
3. SEER₂ is determined based on the Evaporator match listed in this table
4. Subcooling must be measured at condenser liquid valve
5. Superheat must be measured at evaporator outlet at suction line
6. Suction superheat may be achieved by adjusting the TXV in the indoor unit

NHP Thru the Wall Heat Pumps matched with Air Handler - Heating Data

Outdoor Model	Indoor Model	Indoor Model Speed	Rated Capacity (47°F) (Btu/h)	Rated COP ² ₁	Nominal Airflow ² (SCFM)	Rated Capacity (35°F) (Btu/h)	Rated Capacity (17°F) (Btu/h)	HSPF ² ₃	Liquid Subcool ⁴ (°F)	Suction Superheat ^{5,6} (°F)
NHP5183000A-**-**	NAH524MFA-**-**	Black (2)	15,800	3.20	580	12,500	9,900	6.8	12-16	7-11
NHP5243000A-**-**	NAH524MFA-**-**	Blue (3)	19,500	3.20	770	15,300	11,800	6.8	11-15	8-12
NHP5185000A-**-**	NAH524MFA-**-**	Black (2)	16,000	3.30	580	12,900	9,900	7.0	15-19	7-11
NHP5245000A-**-**	NAH524MFA-**-**	Blue (3)	21,000	3.50	770	17,200	12,400	7.2	13-17	8-12
NHP5305000A-**-**	NAH530MFA-**-**	Yellow (4)	23,000	3.30	890	18,900	13,200	7.2	14-18	8-12

1. COP₂ is based on the air handler match listed in this table and is measured at 47 °F OD ambient
2. The airflow values are determined in heating mode
3. HSPF₂ is based on the air handler match listed in this table
4. Subcooling must be measured at the outdoor service valve when running in heating mode at 47 °F OD ambient
5. Superheat must be measured at the compressor suction line using the suction port
6. Suction superheat may be achieved by adjusting the TXV in the outdoor unit

Replacement Parts Guide | 3000 Series

Item	Description	NHP5183000A-**	NHP5243000A-**
1	Contactor	142-62-101	142-62-101
2	Start/Run Capacitor	142-25-375	142-25-375
3	Low Pressure Switch	142-65-028	142-65-028
4	High Pressure Switch	142-65-029	142-65-029
5	Compressor	142-10-272	142-10-273
6	Liquid Service Valve	142-58-614	142-58-614
7	Vapor Service Valve	142-58-615	142-58-615
8	Condenser Coil	142-08-370	142-08-370
9	Coil Drain Pan	143-56-073	143-56-073
10	Motor	142-70-049	142-70-049
11	Fan Blade	142-14-041 ¹	142-14-041 ¹
12	Motor Mount	142-70-103/114 ²	142-70-103/114 ²
13	Base Pan	143-56-071	143-56-071
14	Unit Leveler	143-56-026	143-56-026
15	Access Panel	143-56-093	143-56-093
16	Acc. Panel Patch Plate	143-56-092	143-56-092
17	Top Panel	143-56-029	143-56-029
18	Right Side Panel	143-56-028	143-56-028
19	Left Side Panel	143-56-027	143-56-027
20	Wire Grill	142-69-003A	142-69-003A
21	Radial Fan Mount	143-56-032	143-56-032
22	Touch Up Paint	142-99-630	142-99-630
23	Air Diffuser	143-56-019	143-56-019
24	Air Diffuser Rear	143-56-018	143-56-018
25	Rev. Valve Solenoid	142-06-027	142-06-027
26	Rev. Valve	142-06-031	142-06-031
27	Defrost Cont. Board	142-62-099	42-62-099
28	Outdoor Air Temp. Sensor	142-60-026	142-60-026
29	Outdoor Coil Temp. Sensor	142-60-030	142-60-030
30	Outdoor Air Sensor Bracket	143-56-031	143-56-031
31	Pan Heater	142-99-103	142-99-103
32	Thermal Switch	142-60-028	142-60-028
33	TXV	142-75-168	142-75-168
34	Accumulator	142-55-010	142-55-010
35	Control Box Insert	143-56-081	143-56-081
36	Control Box Frame	143-56-080	143-56-080
37	Control Box Lid	143-56-078	143-56-078
38	Control Box Wire Cover	143-56-079	143-56-079
39	Capacitor Strap	143-56-082	143-56-082
40	Compressor Plug	142-30-418	142-30-418

1. When replacing fan blade, the installer must make sure the fan blade is secured in such a way that two thirds of each fan propeller is below the radial fan mount surface.
2. When repacing 103 motor mount with 114, a set of 4 serated flange nuts will be required.

Replacement Parts Guide | 5000 Series

Item	Description	NHP5185000A-**	NHP5245000A-**	NHP5305000A-**
1	Contactor	142-62-101	142-62-101	142-62-101
2	Start/Run Capacitor	142-25-395	142-25-395	142-25-396
3	Low Pressure Switch	142-65-028	142-65-028	142-65-028
4	High Pressure Switch	142-65-029	142-65-029	142-65-029
5	Compressor	142-10-272	142-10-274	142-10-271
6	Liquid Service Valve	142-58-614	142-58-614	142-58-614
7	Vapor Service Valve	142-58-615	142-58-615	142-58-615
8	Condenser Coil	142-08-377	142-08-376	142-08-376
9	Coil Drain Pan	143-56-014	143-56-014	143-56-014
10	Motor	142-70-056/070 ¹	142-70-056/070 ¹	142-70-056/070 ¹
11	Fan Blade	142-14-040 ²	142-14-040 ²	142-14-040 ²
12	Motor Mount	142-70-103/114 ³ /113 ⁴	142-70-103/114 ³ /113 ⁴	142-70-103/114 ³ /113 ⁴
13	Base Pan	143-56-074	143-56-074	143-56-074
14	Unit Leveler	143-56-005	143-56-005	143-56-005
15	Access Panel	143-56-094	143-56-094	143-56-094
16	Acc. Panel Patch Plate	143-56-092	143-56-092	143-56-092
17	Top Panel	143-56-003	143-56-003	143-56-003
18	Right Side Panel	143-56-002	143-56-002	143-56-002
19	Left Side Panel	143-56-001	143-56-001	143-56-001
20	Wire Grill	142-69-005	142-69-005	142-69-005
21	Radial Fan Mount	143-56-006	143-56-006	143-56-006
22	Touch Up Paint	142-99-630	142-99-630	142-99-630
23	Air Diffuser	143-56-011	143-56-011	143-56-011
24	Air Diffuser Rear	143-56-012	143-56-012	143-56-012
25	Rev. Valve Solenoid	142-06-027	142-06-027	142-06-027
26	Rev. Valve	142-06-031	142-06-031	142-06-031
27	Defrost Cont. Board	142-62-099	42-62-099	42-62-099
28	Outdoor Air Temp. Sensor	142-60-026	142-60-026	142-60-026
29	Outdoor Coil Temp. Sensor	142-60-030	142-60-030	142-60-030
30	Outdoor Air Sensor Bracket	143-56-013	143-56-013	143-56-013
31	Pan Heater	142-99-103	142-99-103	142-99-103
32	Thermal Switch	142-60-028	142-60-028	142-60-028
33	TXV	142-75-168	142-75-168	142-75-168
34	Accumulator	142-55-010	142-55-010	142-55-010
35	Control Box Insert	143-56-081	143-56-081	143-56-081
36	Control Box Frame	143-56-080	143-56-080	143-56-080
37	Control Box Lid	143-56-078	143-56-078	143-56-078
38	Control Box Wire Cover	143-56-079	143-56-079	143-56-079
39	Capacitor Strap	143-56-082	143-56-082	143-56-082
40	Compressor Plug	142-30-418	142-30-418	142-30-418

1. When replacing 056 motor with 070 motor, a new mount will be required.
2. When replacing fan blade, the installer must make sure the fan blade is secured in such a way that two thirds of each fan propeller is below the radial fan mount surface.
3. When replacing 103 motor mount with 114, a set of 4 serrated flange nuts will be required.
4. Motor mount 113 will be required only with 070 motor. 056 motor can be used in either 103 or 114 motor mount.



539 Dunksferry Road | Bensalem, PA 19020 | 215-244-1400 | 1-800-523-7138

THRU-THE-WALL CONDENSING UNIT & HEAT PUMP LIMITED WARRANTY

1. National Comfort Products warrants to its customers that its product shall be free from defects in material and workmanship under normal use and regular service and maintenance as follows:

COMPRESSORS: For five years from the date of original installation.

ALL OTHER PARTS: For all other parts except the Compressor, for two years from the date of original installation.

Customer must register the product within 60 days of purchase. If Customer cannot adequately document date of installation, then, for purposes of determining the warranty period, the date of installation shall be 60 days from the date of purchase. The 2 year parts warranty is effective for units purchased after January 1, 2016.

2. This warranty does not extend to any damages or losses due to misuse, accident, abuse, neglect, normal wear and tear, negligence (other than National Comfort's), unauthorized modification or alteration; use beyond rated capacity; unsuitable power sources or environmental conditions; improper installation, repair, handling, maintenance or application; damage as a result of fire, wind, floods, lightning, or corrosive conditions; or any other cause not the fault of National Comfort. By way of example and without limitation, the following do not constitute a defect in workmanship and materials and are not covered by this warranty: slugging of liquid refrigerant or oil, unstable line voltage, lightning, operating without proper lubrication, and operating without factory provided safeties. Any installation that impairs or impedes air flow negatively impacts performance and causes premature equipment failure that voids this warranty. For example, installation behind a brick facade or the addition of a brick pattern facade, i.e. pigeon holes impedes air flow and shall void this warranty.

3. SOLE WARRANTY

The warranties identified herein constitute National Comfort's sole and exclusive warranties with respect to the goods and are in lieu of and exclude all other warranties, express or implied, arising by operation of law or otherwise, including without limitation, merchantability and fitness for a particular purpose whether or not the purpose or use has been disclosed to National Comfort in specifications, drawings or otherwise, and whether or not National Comfort's goods are specifically designed and/or manufactured by National Comfort for Customer's use or purpose.

4. LIMITATION OF REMEDY

The sole and exclusive remedy for breach of any warranty hereunder (other than the warranty provided herein) shall be limited to repair, replacement, credit or refund of the purchase price to distribution as set forth herein.

National Comfort is not responsible for any other item including but not limited to local transportation, freight, removal of any compressor or part, any labor associated therewith, service or diagnosis calls, refrigerant, or costs for returning any defective compressor or part.

5. LIMITATION OF WARRANTY

NATIONAL COMFORT MAKES NO OTHER WARRANTIES, EXPRESS OR IMPLIED, ORAL OR WRITTEN, RELATED TO THE GOODS, INCLUDING ANY WARRANTY OF MERCHANTABILITY OF FITNESS FOR A PARTICULAR PURPOSE, WHICH ARE EXPRESSLY DISCLAIMED. NATIONAL COMFORT SHALL NOT BE LIABLE FOR SPECIAL, INCIDENTAL, OR CONSEQUENTIAL DAMAGES OR LOSSES FROM ANY CAUSE WHATSOEVER, INCLUDING, WITHOUT LIMITATION, LOSS OF USE, COMMERCIAL PROFITS, OR CUSTOMER GOODWILL, AND ANY OTHER CLAIMS BASED ON CONTRACT OR TORT, WHETHER OR NOT ARISING FROM NATIONAL COMFORT'S NEGLIGENCE.

National Comfort shall not be liable for damages caused by delay in performance and the remedies of Customer set forth in this agreement are exclusive. In no event, regardless of the form of the claim or cause of action (whether based in contract, infringement, negligence, strict liability, other tort or otherwise) shall National Comfort's liability to Customer and/or its customers exceed the price paid by Customer for the specific goods or portion of the goods provided by National Comfort giving rise to the claim or cause of action, and Customer shall indemnify and hold harmless National Comfort for any damages incurred by National Comfort in excess thereof. Customer agrees that in no event shall National Comfort's liability to Customer and/or its customers extend to include incidental, consequential, or punitive damages.

The term "consequential damages" shall include, but not be limited to, loss of anticipated profits, business interruption, loss of use, revenue, reputation and data, costs incurred, including without limitation, for capital, fuel, power and loss or damage to capital or equipment. Customer agrees that all instructions and warnings supplied by National Comfort will be passed on to those persons

Continued on next page

who use the Goods. National Comfort's Goods are to be used in their recommended applications and all warning labels adhered to the Goods by National Comfort are to be left intact.

It is expressly understood that any technical advice furnished by National Comfort before or after delivery in regard to the use or application of the Goods is furnished without charge, and National Comfort assumes no obligation or liability for the advice given or results obtained, all advice being given and accepted at Customer's sole risk.

6. WARRANTY PROCEDURE

For All Warranty Claims. Customer must register the product with National Comfort within 60 days from purchase. Failure to timely register the product may void the warranty. Any claim for warranty shall be made within thirty days of discovery and in any event, within thirty days from removal of the compressor or part from the unit. Failure to make a timely claim shall void the warranty. Prior authorization from National Comfort is required for all warranty claims. Any claim for warranty must be first reported to National Comfort in writing specifying the unit, serial number, date of purchase and date of original installation. Customer shall also request a Return Material Authorization ("RMA") from National Comfort to initiate the warranty claim process. Issuance of an RMA by National Comfort is not an acknowledgment that the defect is covered by this Warranty. Any replacement compressor or part is warranted for the original product warranty, or for one year from the date of shipment of the replacement compressor/part, whichever is later.

A. Compressors. In addition to the above-referenced requirements, Customer is also required to purchase a replacement compressor and return the original compressor to National Comfort at National's discretion. If the defect is reported to National Comfort within one year from the date of original installation or within 20 months from the date of manufacture of the compressor (as determined by the compressor serial number), whichever occurs first, then Customer may take the compressor to any Authorized Copeland Distributor for replacement of said compressor. If the defect is reported to National Comfort after one year from the date of installation or after 20 months from the date of manufacture of the compressor (as determined by the compressor serial number), whichever occurs first, but before the expiration of five years from the date of installation, then the compressor should be returned to National Comfort at National's discretion and Customer shall purchase a new compressor. If National Comfort determines that there is a defect in material or workmanship that is covered by this Warranty, then National shall credit Customer for the cost of the new replacement compressor. If National Comfort determines that the defect in material or workmanship is not covered by this Warranty, then no credit shall be issued. A copy of the invoice of the replacement compressor and completed RMA must accompany the compressor. National Comfort, at its sole discretion, may also require Customer to supply the compressor tag. The failure to follow this procedure shall render the warranty void.

B. Other Parts. In addition to the above-referenced requirements, Customer is required to purchase a replacement part for the original part for which Customer is making a warranty claim. The original part for which warranty is claimed is to be returned to National Comfort at National's discretion, freight prepaid. If National Comfort determines that there is a defect in material or workmanship in the part that is covered by this Warranty, then National Comfort shall credit Customer for the cost of the new replacement part. If National Comfort determines that the defect in material or workmanship is not covered by this Warranty, then no credit shall be issued. A copy of the invoice of the replacement part and completed RMA must accompany the original part for which warranty is claimed. National Comfort reserves the right to request additional documentation. The failure to follow this procedure shall render the warranty void.

7. SHIPPING INSTRUCTIONS

A. Compressors. Returned compressors must be totally secured by use of shipping lugs taken from the replacements compressors and clearly marked with the RMA number. Do not use tape, rags or putty to seal the compressor. Line connections should be sealed with rubber plugs. All scroll compressors must be securely bolted, banded, and stretch wrapped to a skid in the upright position.

B. Parts. All other returned parts must be securely packaged and clearly marked with its corresponding RMA number provided from NCP.





National Comfort Products

A Division of National Refrigeration and Air Conditioning Products, Inc.
539 Dunksferry Road | Bensalem, PA 19020-5908
(800) 523-7138
www.nationalcomfortproducts.com

