

COMFORT PACK

GAS FURNACE INSTRUCTIONS



National Comfort Products

539 Dunksferry Road • Bensalem, PA 19020 • (215) 244-1400 • 1-800-523-7138 • Fax: (215) 244-9579

National Comfort Products

539 Dunksferry Road • Bensalem, PA 19020 • (215) 244-1400 • 1-800-523-7138 • Fax: (215) 244-9579

COMFORT PACK - GAS FURNACE INSTRUCTIONS

General

The gas furnace comes completely assembled, wired, mounted, and factory tested inside the Comfort Pack cabinet. The furnace includes an integral venting system that does not require any field modification or additions. The control system includes a control board with cooling relay, combination gas valve, direct-spark ignition electrode, flame sensor, blocked vent switch, flame rollout sensor, and high temperature limit. The rating plate indicates whether the furnace is equipped and configured for natural or L.P. gas. The furnace includes a condensate disposal system.

THE GAS FURNACES ARE CATEGORY III AND ARE IDENTIFIED AS FOLLOWS:

Part Numbers	Input (Mbh)
14208309/HS038	38
14208308/HS051	51
14208303/HS064	64

INQUIRIES AND PARTS ORDERS SHOULD BE DIRECTED TO:

National Comfort Products
539 Dunksferry Road
Bensalem, PA 19020
Phone: (215) 244-1400
(800) 523-7138
Fax: (215) 639-1674

Installation

The installer shall provide approved gas piping to the furnace including an external manual shutoff valve with 1/8" NPT plugged tapping for test gauge*, external drip leg and external ground joint union. These components and any other requirements shall conform to local building codes. Care must be exercised in locating the unit so that hot flue gas from the furnace conforms to local codes for proximities to public walkways, gas meters, intake vents, etc. In the absence of local codes, the installation must conform with the ANSI Z223.1, National Fuel Gas Code, and/or CAN/CGA-B149, Installation Code.

THE FOLLOWING REGULATIONS APPLY TO THE FURNACE INSTALLATION:

1. The furnace is **NOT** to be used for temporary heating of buildings or structures under construction.
2. The furnace and its appliance main gas valve must be disconnected from the gas supply piping system during any pressure testing of that system at test pressures in excess of 1/2 PSI (3.5 KPA). The furnace must be isolated from the gas supply piping system by closing the equipment shut-off valve during any pressure testing of the gas supply

piping system at test pressures equal to or less than 1/2 PSI (3.5KPA).

3. If the furnace is installed in a residential garage, it must be installed so the burner and the ignition source are located not less than 18 inches (457 mm) above the floor and the furnace must be located or protected to avoid physical damage by vehicles.
4. Provisions for adequate combustion and ventilation air in accordance with section 5.3, air for combustion and ventilation, of the National Fuel Gas Code, ANSI Z223.1, or sections 7.2, 7.3, or 7.4 of CAN/CGA-B149, installation codes, or applicable provisions of the local building codes.
5. The furnace uses outside air for combustion. Excessive exposure to contaminated combustion air will result in safety and performance related problems. Avoid installing the unit near sources or vents that may contain the following contaminants:
 - a. Permanent Wave Solutions
 - b. Chlorinated Waxes and Cleaners
 - c. Chlorine-Based Swimming Pool Chemicals
 - d. Water Softening Chemicals
 - e. De-Icing Salts or Chemicals
 - f. Carbon Tetrachloride
 - g. Halogen Type Refrigerants
 - h. Cleaning Solvents (such as Perchloroethylene)
 - i. Printing Inks, Paint Removers, Varnishes, etc.
 - j. Hydrochloric Acid
 - k. Cements and Glues
 - l. Antistatic Fabric Softeners for Clothes Dryers
 - m. Masonry Acid Washing Materials
6. The Comfort Pack unit shall not be installed directly on carpeting, tile, or other combustible material other than wood flooring.
7. The Comfort Pack may be installed with zero clearances on all sides. It is recommended that a minimum of 29" of unobstructed area be provided in front of the access panels for routine service and chassis removal.
8. The grilles on the outside of the units should be kept clear of obstructions to permit proper operation of the furnace vent system.
9. The vent system is designed for proper operation under all weather conditions and for winds up to 40 mph. Do not alter or extend the vent outlet.
10. The furnace venting system is an integral, independent, complete, and tested part of the Comfort Pack unit. It is not intended for field connection to any other venting system. Do not modify, alter or connect to the vent system in the unit.

* 1/8" NPT plugged tapping for test gauge not permitted in Massachusetts.

11. If the Comfort Pack is installed so that supply ducts carry air circulated by the furnace to areas outside the space containing the furnace, the return air shall also be handled by a duct(s) sealed to the furnace casing and terminating outside the space containing the furnace. The supply air duct should be equipped with a removable inspection panel to allow for future inspections of the heat exchanger.
12. The Comfort Pack unit contains a 16" x 25" x 1" air filter located on the cooling chassis. Replacement of this filter with an equivalent type is necessary to maintain the performance of the furnace. The condition of the filter should be checked at least monthly. The air filter may be accessed by shutting off the unit and removing the lower access panel. The air filter may be removed by sliding it out of the filter holders. The unit should not be operated without the filter and lower access panel in place.
13. The installation is to be adjusted to obtain a temperature rise within the range(s) specified on the appliance rating plate.

Furnace Service

Warning: Power must be disconnected before servicing.

The air filter located on the cooling chassis should be maintained regularly. It should be checked at least monthly. Longer intervals between servicing may be justified depending upon the hours of unit operation and the cleanliness of the environment. A dirty air filter can adversely affect both heating and cooling operations, reduce heat exchanger life and increase energy usage.

Caution: Label all wires prior to disconnection when servicing controls. Wiring errors can cause improper and dangerous operation.

The furnace is designed to operate efficiently for many heating seasons with minimal servicing. The following procedures should be done on an annual basis, more often if the unit is in a dusty environment:

1. Clean all dirt, lint and grease from the combustion air openings and venter motor. If an accumulation of dirt, dust or lint is found in the burner/control compartment, it will be necessary to clean the compartment and to provide "burner service" as outlined below.
2. Inspect the heat exchanger. If the supply air is ducted, remove the inspection panel from the duct to observe the heat exchanger. Clean if necessary. Check for cracks or holes. Replace the heat exchanger if any cracks or holes are found. Do not attempt to repair a damaged heat exchanger. Also, refer to "burner service" for additional information on inspecting the heat exchanger.
3. Check the burner for scale, dust or lint accumulation. Clean if needed.
4. Check the vent system for soundness. Replace any parts that do not appear sound.
5. Check the wiring for any damage and replace if necessary.

6. The ignitor assembly may be removed and cleaned using emery cloth. The spark gap should be set at 1/8".
7. The venter motor bearings are permanently lubricated. Lubrication of the motor is not recommended.

Burner Orifice:

This device generally does not need cleaning and only needs to be changed when a change of gas is involved. The orifice sizes that are used with natural or L.P. gas are shown on the rating plate. Orifices and labels are available from National Comfort Products when the gas is being field converted to a different gas than shown on the rating plate and label. It is also necessary to reset the combination gas valve to the proper outlet pressure shown on the rating plate. To prevent dropping the orifice into the burner housing, temporarily place something the size of a credit card across the venturi. Be careful not to damage the venturi tube and/or the bracket.

Burner Service:

The need to disassemble and clean the burner assembly is indicated when there is an accumulation of dirt, dust or lint in the burner/control compartment. After cleaning the compartment, remove the burner as described below:

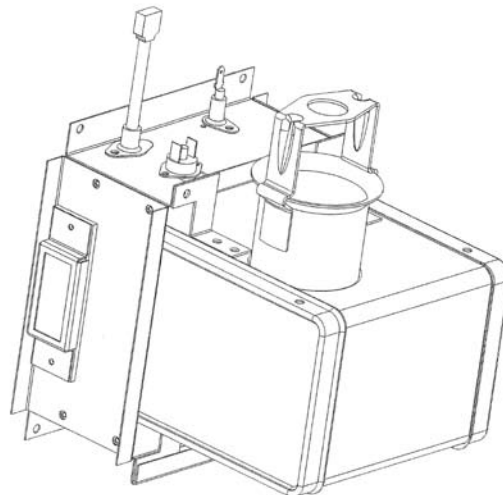

1. Shut the gas supply off ahead of the combination valve.
2. Turn off the electric supply.
3. Remove the entire upper access panel to expose the heat exchanger section and the burner/control compartment.
4. Carefully loosen and remove the gas supply tube.
5. Mark and disconnect the pressure switch wires. Disconnect the tubing and remove the pressure switch.
6. Locate the secondary air shield end cap. Remove the four screws holding it to the air shield and remove the end cap.
7. Locate the upper burner brackets (one on each side). Remove the two screws (one on each side) that attach the burner assembly to the secondary air shield assembly.
8. Tilt the burner assembly slightly and lift it free from the retaining track under the burner assembly. Remove the burner assembly from the cabinet.

9. With the burner assembly removed, shine a flash light on the burner ribbons. Look for carbon buildup, scale, dust, lint, and/or anything that might restrict flow through the spaces between the burner ribbons. Holding the burner assembly so that any foreign material will fall away from the burner, use a stiff bristle brush to loosen and remove any foreign materials.

If the burner is excessively dirty, remove one of the burner end caps. Remove the four screws that hold the end cap to the burner housing. Lightly tap the end cap to remove it. Clean all foreign material from the burner and venturi. After the burner is thoroughly clean, replace the end cap making certain that it is tight against the burner housing.

VERIFY PROPER OPERATION AFTER SERVICING.

NOTE: If any of the burner components are damaged or deteriorated, replace the burner assembly.

REPLACEMENT PARTS GUIDE

ITEM	DESCRIPTION	PART NO.
1	Complete Furnace Assembly 38 Mbh	14208309
2	Complete Furnace Assembly 51Mbh	14208308
3	Complete Furnace Assembly 64 Mbh	14208303
4	Flame Rollout Switch	14208314
5	Orifice Adapter	14208315
6	Orifice Adaptor Lock Nut	14208316
7	DSI Electrode Assembly	14208317
8	Flame Sensor	14208318
9	DSI Integrated Control Board w/Cooling Relay	14208319
10	High Temperature Limit Thermostat	14208320
11	Pressure Switch	14208324
12	High Altitude Pressure Switch	14208325
13	Combination Gas Valve	14208326
14	Venter Tube Assembly	14208327
15	Venter Wheel Motor Assembly	14208328
16	Heat Exchanger Assembly - 38 Mbh	14208329
17	Heat Exchanger Assembly - 51 Mbh	14208330
18	Heat Exchanger Assembly - 64 Mbh	14208331
19	Full Burner Body Assembly - 38 Mbh	14208332
20	Full Burner Body Assembly -51 Mbh	14208333
21	Full Burner Body Assembly - 64 Mbh	14208334
22	Control Plug Assembly (9 wire)	14208335
23	Natural Gas Orifice - 38 Mbh	14208336
24	Natural Gas Orifice - 51 Mbh	14208337
25	Natural Gas Orifice - 64 Mbh	14208338
26	L.P. Gas Orifice - 38 Mbh	14208339
27	L.P. Gas Orifice - 51 Mbh	14208340
28	L.P. Gas Orifice - 64 Mbh	14208341
29	Control Plug Assembly (5 wire)	14208342
30	1/2" 90° Street Elbow Pipe	14208349
31	1/2" 90° Elbow Pipe	14208350
32	1/2" x 8" Black Pipe Threaded Both Ends	14208351

For proper performance and safety, it is important that replacement parts be obtained from National Comfort Products. Please refer to the parts list at left for the part numbers:

National Comfort Products
 539 Dunksferry Road
 Bensalem, PA 19020
 (215) 244-1400
 1-800-523-7138
 Fax: (215) 244-9579

Wiring Schematic/Gas Heat

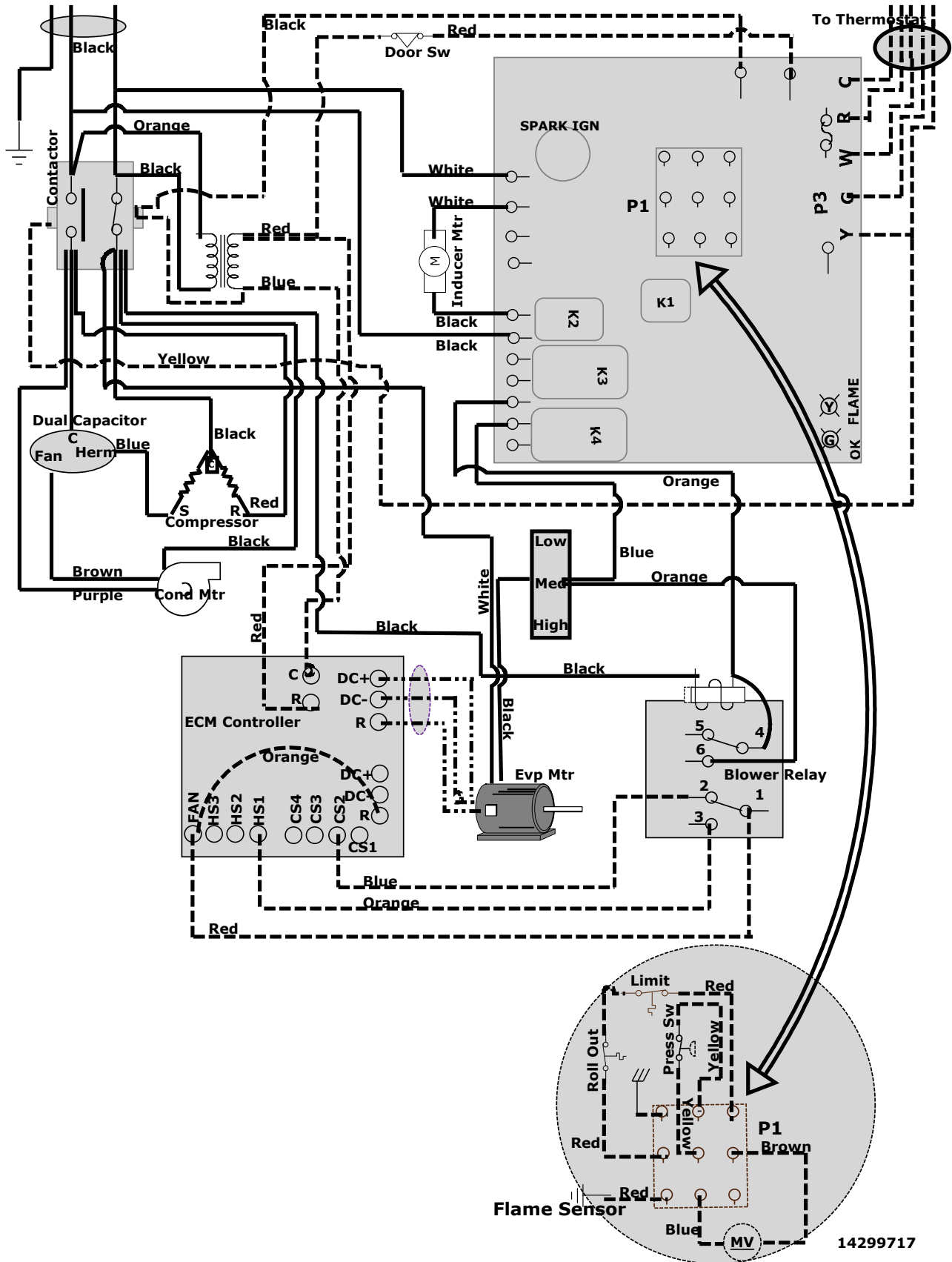

14299717

Legend

DSI INTEGRATED CONTROL MODULE	
CONTROL STATUS	GREEN LED
STEADY ON	Normal operation, no call for heat
FAST FLASH	Normal operation, call for heat
1 FLASH	In lockout from failed ignition or flame loss
2 FLASH	Pressure switch does not close within 30 seconds
3 FLASH	Limit switch or rollout switch open
4 FLASH	Limit switch is closed before venter is energized
STEADY OFF	Internal control fault or no power
FLAME STATUS	YELLOW LED
STEADY ON	Flame sensed
SLOW FLASH	Weak flame (current below 1.0 microamps = +/-50%)
FAST FLASH	Undesired flame (valve open and no call for heat)

FAN OFF DELAY		
TIME	SWITCH	
	1	2
90	OFF	ON
120	OFF	OFF
160	ON	OFF
180	ON	ON

TEST

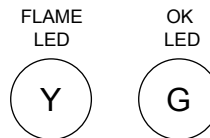

FIELD CONTROL WIRING		
TOTAL WIRE LENGTH	DISTANCE FROM UNIT TO CONTROL	MIN. RECOMMENDED WIRE GAUGE
150'	75'	#18 GAUGE WIRE
250'	125'	#16 GAUGE WIRE
350'	175'	#14 GAUGE WIRE

OPERATION SEQUENCE

1. SET THERMOSTAT AT LOWEST SETTING.
2. TURN ON MANUAL GAS VALVE.
3. TURN ON POWER TO UNIT.
4. SET THERMOSTAT AT DESIRED SETTING.
5. THERMOSTAT CALLS FOR HEAT, ENERGIZING THE VENTER MOTOR.
6. VENTER PRESSURE SWITCH CLOSSES, FIRING UNIT.
7. BURNER FLAME IS SENSED, AND IN 30 SECONDS THE FAN MOTOR IS ENERGIZED.
8. IF THE FLAME IS EXTINGUISHED DURING MAIN BURNER OPERATION, THE INTEGRATED CONTROL SYSTEM CLOSSES THE MAIN VALVE AND MUST BE RE-SET BY INTERRUPTING POWER TO THE CONTROL CIRCUIT (SEE LIGHTING INSTRUCTIONS).

NOTES

1. THE FOLLOWING CONTROL IS A FIELD-INSTALLED OPTION: THERMOSTAT.
2. DOTTED WIRING INSTALLED BY OTHERS.
3. CAUTION: IF ANY OF THE ORIGINAL WIRING AS SUPPLIED WITH THE APPLIANCE MUST BE REPLACED, IT MUST BE REPLACED WITH WIRING MATERIAL HAVING A TEMPERATURE RATING OF AT LEAST 105°C EXCEPT FOR SENSOR LEAD WIRE AND LIMIT WIRING WHICH MUST BE 150°C.
4. USE 18 GAUGE WIRE FOR ALL LOW VOLTAGE WIRING ON THE UNIT OR FOLLOW CHART ABOVE.
5. LINE AND FAN MOTOR BRANCH WIRE SIZES SHOULD BE OF A SIZE TO PREVENT VOLTAGE DROPS BEYOND 5% OF SUPPLY LINE VOLTAGE.
6. GROUND WIRE IS USED ONLY ON MODEL 64 UNITS.

