

LINE VOLTAGE: _____
 LOW VOLTAGE: - - - - -

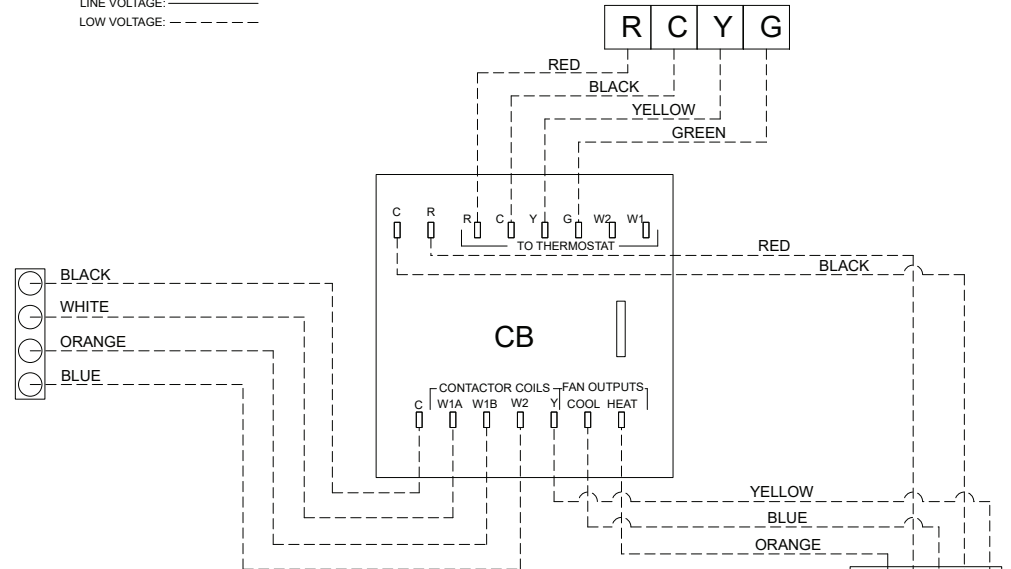

FACTORY SPEED SETTINGS		SPEED TERMINAL
ORANGE - FAN	BLUE - COOL	1 - HIGH
FAN ONLY = 5	.75 TON = 5	2 - MED HIGH
	1 TON = 4	3 - MED
	1.5 TON = 3	4 - MED LOW
	2 TON = 2	5 - LOW

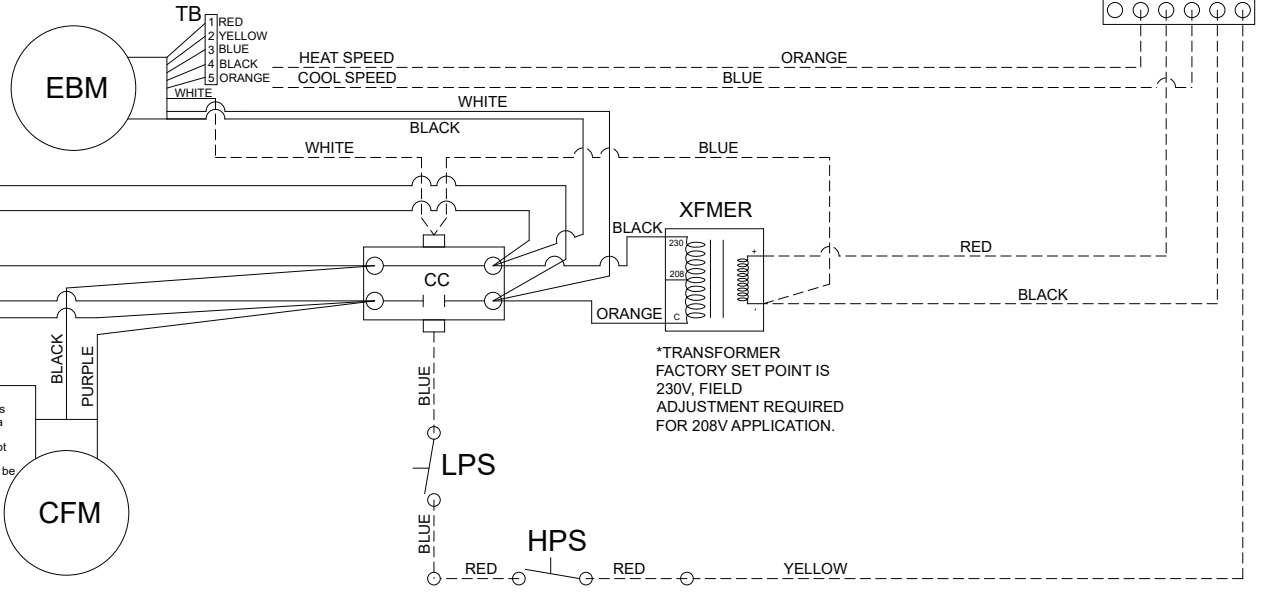

*TRANSFORMER
 FACTORY SET POINT IS
 230V, FIELD
 ADJUSTMENT REQUIRED
 FOR 208V APPLICATION.



539 DUNKSFERRY RD.
 Bensalem, Pa. 19020
 Phone: 800-523-7138
 FAX: 215-639-1674

**WIRING DIAGRAM
 COMFORT PACK ELECTRIC
 U-SERIES 15 KW**

DRAWN BY	DATE	JOB NUMBER	PART NUMBER
BS	10/30/2023	CPE4UB-A 15	14299195

CAP - DUAL CAPACITOR
 CB - CONTROL BOARD
 CC - COMPRESSOR CONTACTOR
 CFM - CONDENSER FAN MOTOR
 COMP - COMPRESSOR
 EBM - EVAPORATOR BLOWER MOTOR

HPS - HIGH PRESSURE SWITCH
 LPS - LOW PRESSURE SWITCH
 XFMR - TRANSFORMER
 TB - TERMINAL BOARD