

LINE VOLTAGE: _____
 LOW VOLTAGE: _____

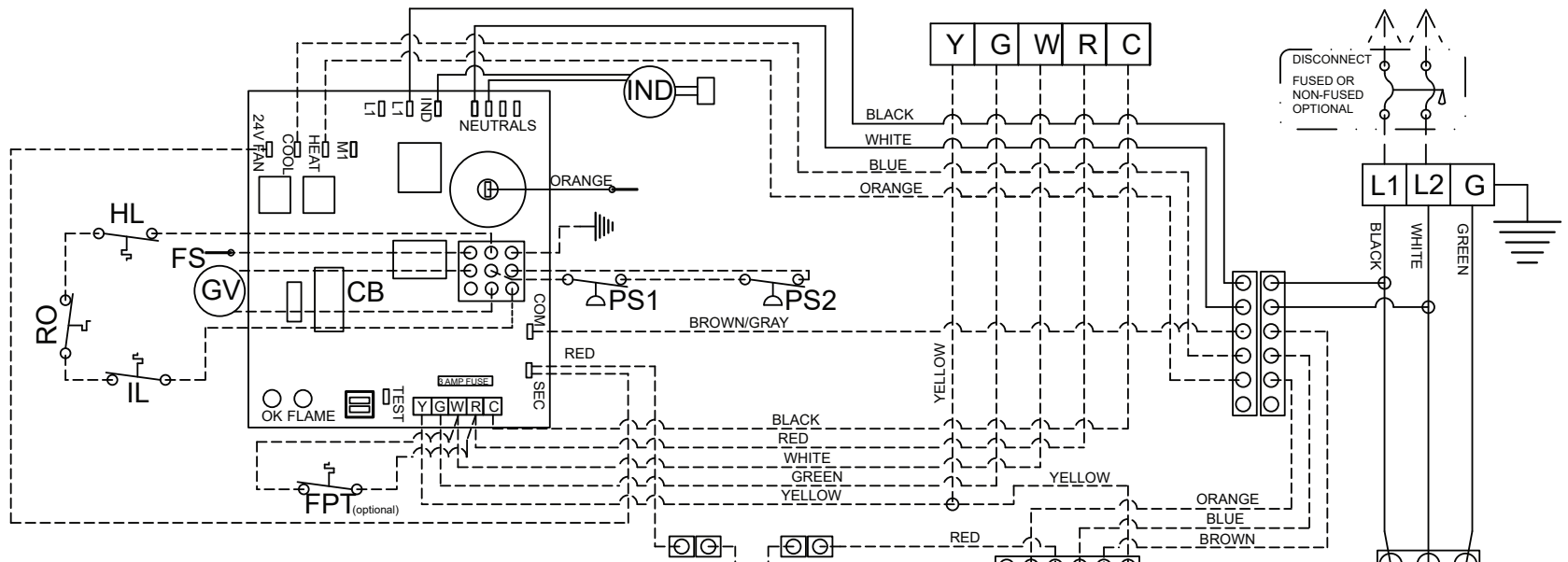

SPEED CHART	
ORANGE - HEAT	BLUE - COOL
25MBTU = 4/5	1 TON = 4
32MBTU = 3/4	1.5 TON = 2
43MBTU = 1/2	2 TON = 2
50MBTU = 1/2	

SPEED TERMINAL	
1 - HIGH	
2 - MED HIGH	
3 - MED	
4 - MED LOW	
5 - LOW	

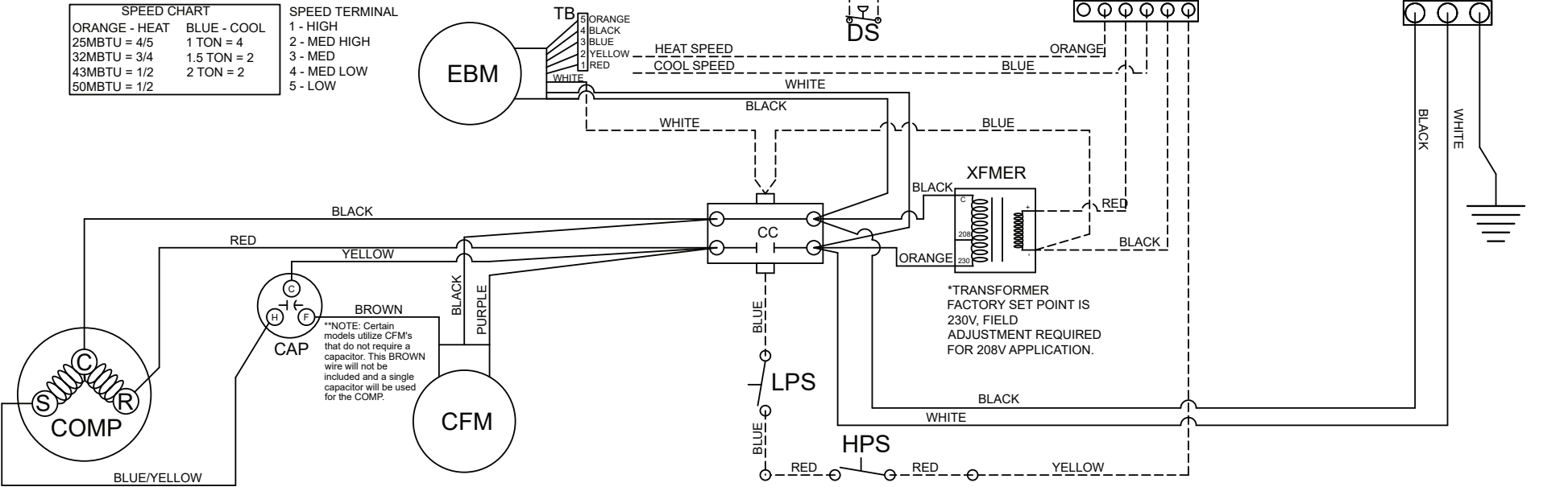

NATIONAL COMFORT PRODUCTS

539 DUNKSFERRY RD.
 Bensalem, Pa. 19020
 Phone: 800-523-7138
 FAX: 215-639-1674

**WIRING DIAGRAM
 COMFORT PACK GAS CHS
 U-SERIES**

DRAWN BY	DATE	JOB NUMBER	PART NUMBER
BS	8/4/2022	CP94UA-A	14299192

- CAP - DUAL CAPACITOR
- CB - CONTROL BOARD
- CC - COMPRESSOR CONTACTOR
- CFM - CONDENSER FAN MOTOR
- COMP - COMPRESSOR
- DS - DOOR SWITCH
- EBM - EVAPORATOR BLOWER MOTOR
- FPT - FREEZE PROTECTION TSTAT

- FS - FLAME SENSOR
- GV - GAS VALVE
- HL - HIGH LIMIT SWITCH
- IL - INDUCER LIMIT
- IND - INDUCER MOTOR
- DS - DOOR SWITCH
- HPS - HIGH PRESSURE SWITCH
- PS1 - PRESSURE SWITCH (1)

- PS2 - PRESSURE SWITCH (2)
- RO1 - ROLLOUT SWITCH
- SI - SPARK IGNITOR
- TB - TERMINAL BOARD
- XFMR - TRANSFORMER